

# THE ASSIST GUIDEBOOK TO THE ACCESSIBLE HOME

## Practical Designs for Home Modifications and New Construction

### **This publication was prepared by ASSIST Inc**

ASSIST Inc is a non-profit Community Design Center that provides architectural design, community planning and development assistance to non-profit and community groups, and housing and accessibility design assistance to low income households or persons with disabilities. ASSIST was founded in 1969 by the Graduate School of Architecture at the University of Utah and the Utah Society of the American Institute of Architects.

### **ASSIST Inc**

Director  
Accessibility Design Coordinator  
Home Repair Coordinator

Roger Borgenicht  
Melissa Hoffmann  
David Woodman

### **Principal Authors**

#### 2005 Edition

Roger Borgenicht  
Melissa Hoffmann  
Katrina Mustoe  
Antonia Vazquez

#### 2002 Edition

Roger Borgenicht  
Melissa Hoffmann  
Robert Matkin  
Benjamin Schreiter

#### 1998 Printing

Roger Borgenicht  
Jeanne Clark  
Eric Thompson  
Brian Zait

### **Structural Engineering Consultant**

Charles H. Richardson, P. E

Copyright, 2005 by  
ASSIST Inc  
218 East 500 South  
Salt Lake City, Utah 84111  
(801) 355-7085

All rights reserved. No part of this  
book may be reproduced in any  
form without written permission  
from ASSIST Inc.



# Disclaimer

ASSIST Inc has made every effort to insure that the information contained in this guidebook is complete and accurate. However, the authors and publisher are not responsible for any errors or omissions and no warranties are made or implied. No guarantee is made as to accuracy or completeness of the information. No representation is made as to whether the information complies with any building code, law, or regulation.

The information contained herein is in the nature of general guidance, examples, and suggestions. This guidebook is not in any way intended to substitute for appropriate architectural, engineering, or contractor advice. Actual utilization of the information herein will require adaptation and modification to the specific person, building, and property to assure compliance with building codes, engineering requirements, and safety standards, which may vary from locality to locality and person to person.

Products shown herein are included as examples of available products. No endorsement, recommendation, or evaluation of these products or their use is intended or implied.

The authors and publisher shall not be liable nor responsible for any loss or damage arising from the information contained in this guidebook or its use.



# Acknowledgments

We would like to thank the many individuals, organizations, and manufacturers who helped make this book a reality. The efforts of the following individuals and groups are greatly appreciated. These individuals and organizations gave financial support, reviewed the guidebook, provided information, and supplied photos.

## For continued support and review

### The ASSIST Inc Board of Trustees:

|                |                |
|----------------|----------------|
| Mary Allen     | Chris Quann    |
| John Combe     | Maged Senbel   |
| Mary Ann Cowen | Soren Simonsen |
| Ann Floor      | Lisa Whoolery  |
| Don Mahoney    |                |

### The Independent Living Centers of Utah:

Active Re-Entry in Price  
Central Utah Center in Provo  
Options for Independence in Logan  
Red Rock Independent Living Center in St. George  
Utah Independent Living Center in Salt Lake City  
Tri-County Center in Ogden

## For review, suggestions, and photographs

|                      |                    |
|----------------------|--------------------|
| Debbie Adams         | William Miller     |
| Wayne Bingham        | Martha Mitchell    |
| Marty Blair          | Kinde Nebeker      |
| Tom Brennan          | Gary Owens         |
| Harvey Boyd          | Rex Pace           |
| Rebecca Christiansen | Stephanie Peterson |
| Mary Ann Cowen       | Ken Reid           |
| Karen Denton         | Tara Rollins       |
| Steve Ehninger       | Eleanor Smith      |
| Tom England          | Mark Smith         |
| Diana Epperson       | Eric Strindberg    |
| Roger Evans          | Barbara Toomer     |
| Dave Fitzsimmons     | Maree Webb         |
| Matt Larsen          | David Woodman      |
| Debra Mair           | Margaretta Woolley |
| Janice McCullough    | Lynn Zaritsky      |

---

## Publication of 2005 Edition



American Express  
Center for Community  
Development

## For accessibility design program support

Community Development Block Grant funds

|                  |              |
|------------------|--------------|
| Salt Lake County | West Jordan  |
| Salt Lake City   | Taylorsville |
| South Salt Lake  | Midvale      |
| Murray           | Holladay     |
| Sandy            | Draper       |

Utah Dept. of Community and Economic Development  
Utah Governor's Council for People with Disabilities  
American Express Center for Community Development  
Morgan Stanley Bank

## Previous Editions

### 1998 Edition

Utah Arts Council  
United Way  
Utah Dept. of Community and Economic Development  
Utah State Office of Rehabilitation  
This project is supported by a grant from the Utah Arts Council and the National Endowment for the Arts, Washington D.C.

### 2002 Edition

American Express Centurion Bank  
Washington Mutual Bank Foundation

## **For the use of illustrations and product materials**

**Access Industries**, 4001 East 1038th Street, Grandview, MO 64030

**American Standard Inc.**, One Centennial Avenue, P. O. Box 6820, Piscataway, NJ 08855

**Apex Dynamics**, 6225 Shiloh Road, Unit C, Alpharetta, GA 30005

**Bemis Manufacturing Company**, 300 Mill St, Sheboygan Falls, WI 53085

**Concord Elevator Inc.**, 7900 Nelson Road, Panarama City, CA 91402

**Essex Electronics Inc.**, 1130 Mark Ave., Carpinteria, CA 93013

**Frank Lloyd Wright Foundation**, Taliesin West, P.O. Box 4430, Scottsdale, AZ 85261

**JH Industries, Inc.**, 1981 East Aurora Road, Twinsburg, OH 44087

**Meditex Ltd.**, Wentworth House, 9 Kings Rd, Fleet, Hampshire GU513SE

**Robert I. Merrill Co**, 575 West 3900 South, Salt Lake City, UT 84123

**NT Falcon Lock**, 2850 Orbiter St., Brea, CA 92821

**Pemko**, 4226 Transport St., Ventura, CA 93006

**Porta-Ramp, Crump Products Inc.**, 952 South 3rd Street, Louisville, KY 40203

**Prairie Heritage Cabinetry and Furniture**, 27111 Independence Ave-  
Bldg. B, Sioux Falls, SD 57108

**Prairie View Industries, Inc.**, Fairbury, NE 68352-0575

**Savaria Inc.**, 1101 Highway #13 Laval, Quebec H7W 4V3, Canada

**Simpson Strong-Tie Company, Inc**, 4637 Clabot Drive, Pleasanton, CA 94588

**Schlage Lock Company**, 2401 Bayshore Blvd., San Francisco, CA 94134

**Sunset Publishing Co.**, *Sunset Decks, Ideas and Plans-Building Techniques*, copyright 1990, Sunset Books Inc., Menlo Park, CA 94025

**The National Wheel-O-Vator Co., Inc.**, 509 W. Front St., Roanoke, IL 61561

## **For the contribution of computer support and software**

**Adobe Systems Inc.**, 345 Park Ave., San Jose, CA 95110-2704

**Autodesk, Inc.**, 111 McInnis Parkway, San Rafael, CA 94903

Dan Peay, **Microsoft**, 735 South 475 East, Centerville, UT 84014

Paul Slack, **lomega**, 1821 W. lomega Way, Roy, UT 84067

Derek Bingman, **Graduate School of Architecture**, University of Utah, Salt Lake City, UT

**Monsen Engineering**, 960 South Main, Salt Lake City, UT 84101

**Gillies Stransky Brems Smith Architects**, 357 West 200 South, Salt Lake City, UT 84101

**Valentiner Crane Brunjes Onyon Architects**, 524 South 600 East, Salt Lake City, UT 84102

---

# Table of Contents

|                     |          |
|---------------------|----------|
| <b>INTRODUCTION</b> | <b>2</b> |
|---------------------|----------|

|                            |          |
|----------------------------|----------|
| <b>STANDARD DIMENSIONS</b> | <b>4</b> |
|----------------------------|----------|

|                   |          |
|-------------------|----------|
| <b>HOME ENTRY</b> | <b>6</b> |
|-------------------|----------|

## Ramps

|                   |    |
|-------------------|----|
| Ramp Planning     | 10 |
| Ramp Construction |    |
| • Wood            | 20 |
| • Metal           | 41 |
| • Concrete        | 42 |

|                |    |
|----------------|----|
| Low Rise Steps | 44 |
|----------------|----|

|                              |    |
|------------------------------|----|
| Hardware, Lumber, & Finishes | 46 |
|------------------------------|----|

|             |    |
|-------------|----|
| Porch Lifts | 48 |
|-------------|----|

|                        |           |
|------------------------|-----------|
| <b>INTERIOR ACCESS</b> | <b>50</b> |
|------------------------|-----------|

|          |    |
|----------|----|
| Doorways | 50 |
|----------|----|

|                         |    |
|-------------------------|----|
| Lifts                   | 52 |
| Stair Lifts             |    |
| Inclined Platform Lifts |    |
| Overhead Lifts          |    |

|           |    |
|-----------|----|
| Elevators | 53 |
|-----------|----|

|                               |           |
|-------------------------------|-----------|
| <b>BATHROOM MODIFICATIONS</b> | <b>54</b> |
|-------------------------------|-----------|

|                               |           |
|-------------------------------|-----------|
| <b>Typical 5'x8' Bathroom</b> | <b>54</b> |
| Tub Seat / Transfer Bench     |           |
| Curb Shower                   |           |
| Roll-In Shower                |           |

|                             |           |
|-----------------------------|-----------|
| <b>Bathroom Alterations</b> | <b>56</b> |
| Tub Modifications           |           |
| Curb Shower                 |           |
| Roll-In Shower              |           |
| Cabinet Modifications       |           |

|                              |           |
|------------------------------|-----------|
| <b>KITCHEN MODIFICATIONS</b> | <b>60</b> |
|------------------------------|-----------|

|                                |           |
|--------------------------------|-----------|
| <b>Typical Kitchen Layouts</b> | <b>60</b> |
| Roll-Under Sinks               |           |
| Cabinets and Breadboards       |           |
| Ranges and Ovens               |           |
| Shelving                       |           |

|                              |           |
|------------------------------|-----------|
| <b>NEW HOME CONSTRUCTION</b> | <b>64</b> |
|------------------------------|-----------|

|                                 |           |
|---------------------------------|-----------|
| <b>Accessible Home Features</b> | <b>65</b> |
|---------------------------------|-----------|

|                      |           |
|----------------------|-----------|
| <b>No-Step Entry</b> | <b>66</b> |
|----------------------|-----------|

|                        |           |
|------------------------|-----------|
| <b>Bathroom Access</b> | <b>68</b> |
|------------------------|-----------|

|                       |           |
|-----------------------|-----------|
| <b>Kitchen Access</b> | <b>72</b> |
|-----------------------|-----------|

|                               |           |
|-------------------------------|-----------|
| <b>Accessible Floor Plans</b> | <b>76</b> |
|-------------------------------|-----------|

**LEVELS OF ACCESSIBILITY** 78

Visitability Features 80

Usability Features 82

Accessibility Features 83

**RESOURCES** 84

Resources in Utah

Financial Assistance

**REFERENCES** 88

Publications

Design Guidelines

Technical Assistance

**INDEX** 90





# INTRODUCTION

---

## The User

Many people with physical disabilities lead active roles in our society. Today there is a new focus on helping people with physical disabilities to function independently at home, in the work place, and in the community.

Initially accessibility design began at the level of public facilities and is currently mandated by federal guidelines and local municipal building codes for public, commercial, and multifamily housing.

Surprisingly, our homes are still places where accessibility may be the most difficult. If a person becomes disabled in any capacity, whether temporary or permanent, mobility in their home may be significantly impaired. The most common difficulties involve entry into the home, use of the bathrooms and kitchen, and navigating doorways and halls.

This book addresses these issues and provides planning and construction guidance for modifying existing homes and also how to include a range of accessibility features into new homes. The goal is to provide practical information for the do-it-yourself designer as well as for contractors, builders, and architects.

When designing for a person with a disability, it is important to know their capabilities and strength. This helps to determine the degree of assistance that is needed. It is also helpful to know if the disability is temporary or permanent, if it will become more severe over time, and the number of people the modification may need to accommodate.

Know the type of mobility aid or device and the frequency of use. A person using a walker most of the time may also use a wheelchair some of the time.

Also, take into account the capability and limitations of the mobility aid. Walkers and wheelchairs come in various types and sizes. Each has a different dimension, turning radius, and height.

Measure the chair or walker in the planning and design process, including allowances for hands and arms at the sides. Power wheelchairs may have different space requirements for maneuverability than manual chairs. Keep in mind that some people, or their family and friends, may use both a manual and a power wheelchair.

There are various code requirements and guidelines related to accessibility design and are a necessary tool in planning. However, guidelines cannot take the place of designing for a individual's specific needs and desires.

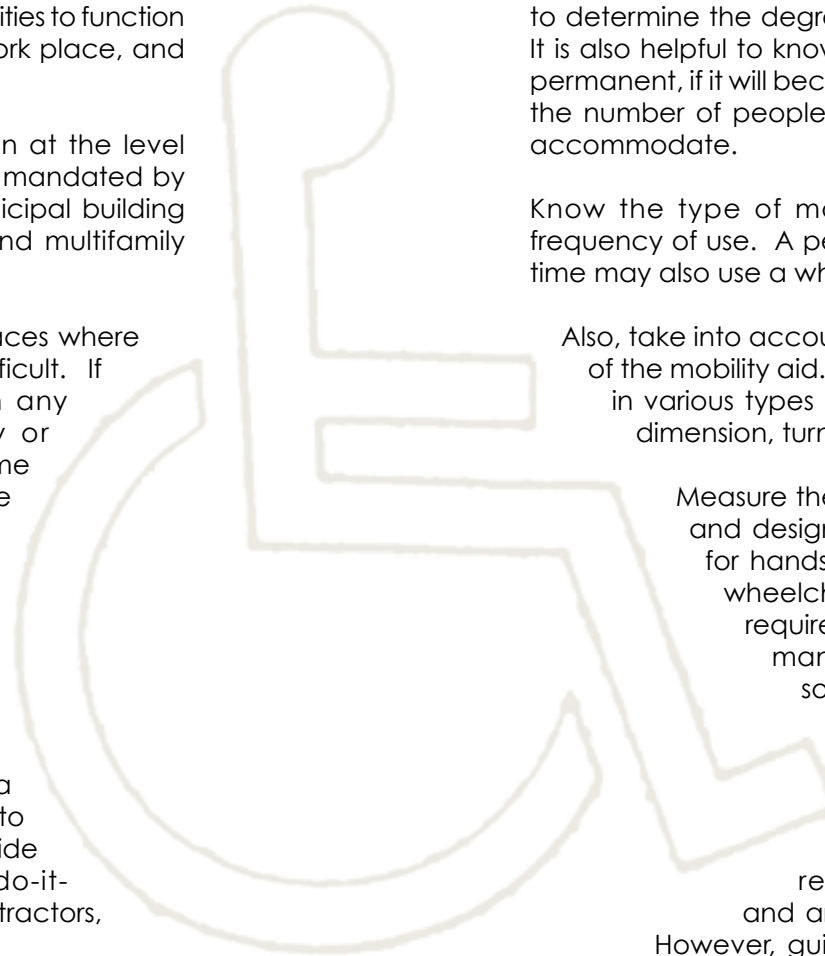



# STANDARD DIMENSIONS



Standard Ramp - 1 in 12  
**"A foot of ramp for each inch of rise"**

## Ramps

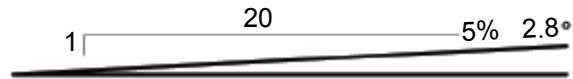

Sloped Pathway - 1 in 20

## Pathways



Ramp Width

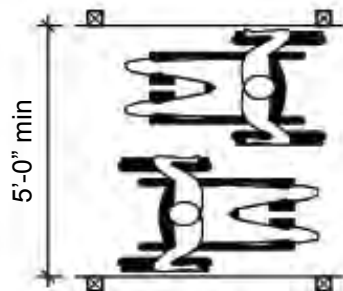
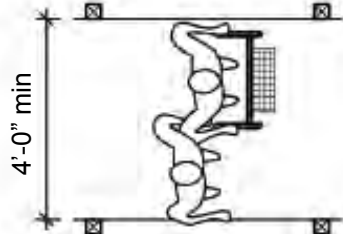

## Door Thresholds

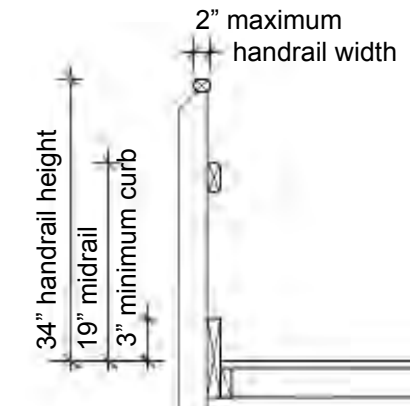
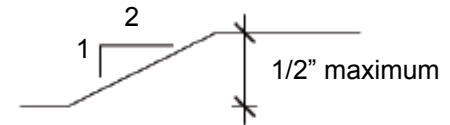
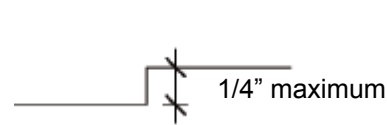

Ramp Rails and Curbs

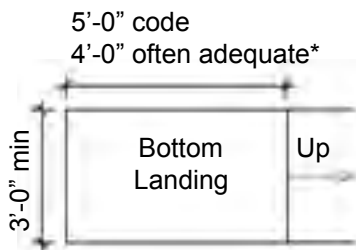

Ramp Landings

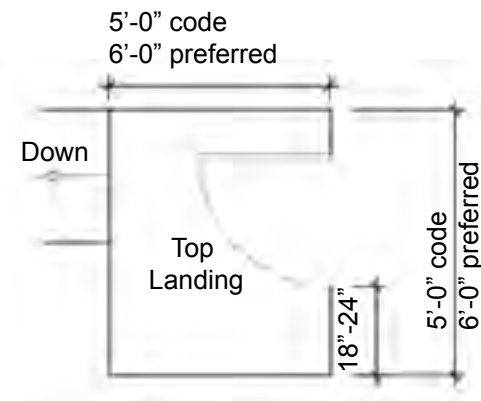
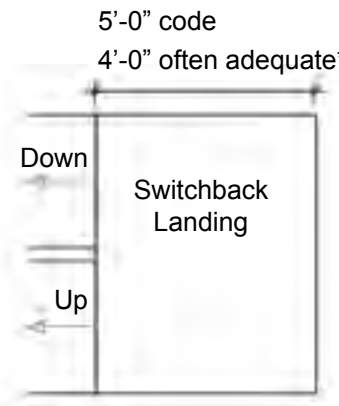
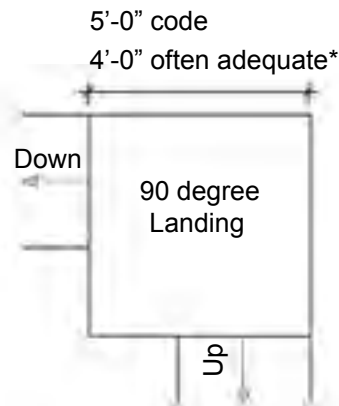

\*must be approved by building official

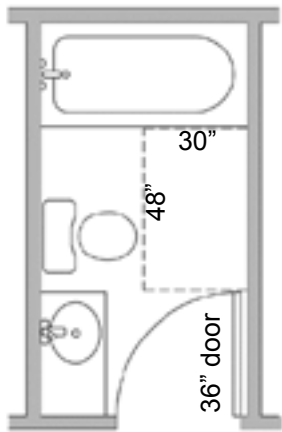

**Clear Floor Space**

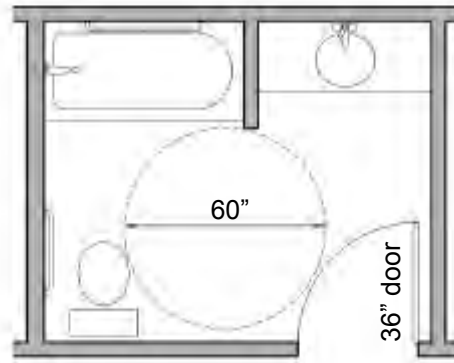

**Wheelchair Turning Space**

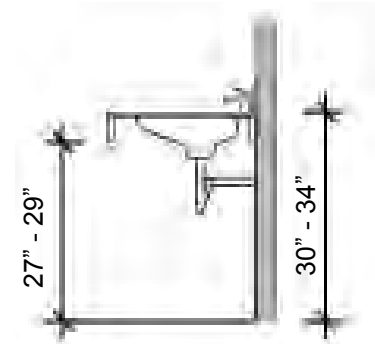

**Sink and Counter Clearances**

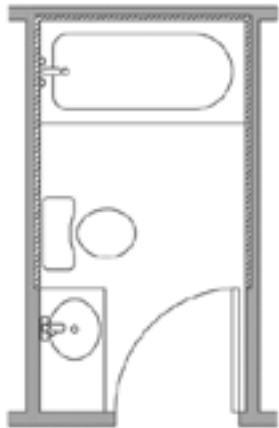

**Grab Bar Reinforcement**

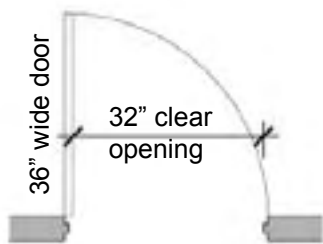
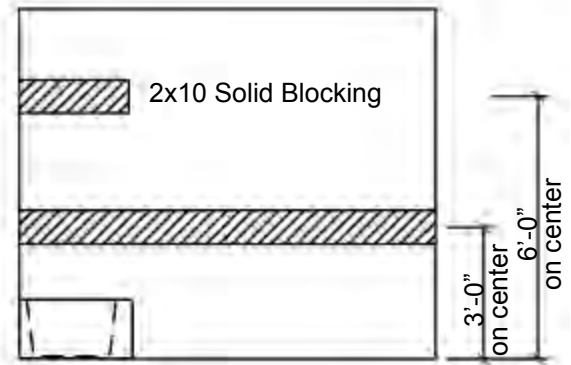
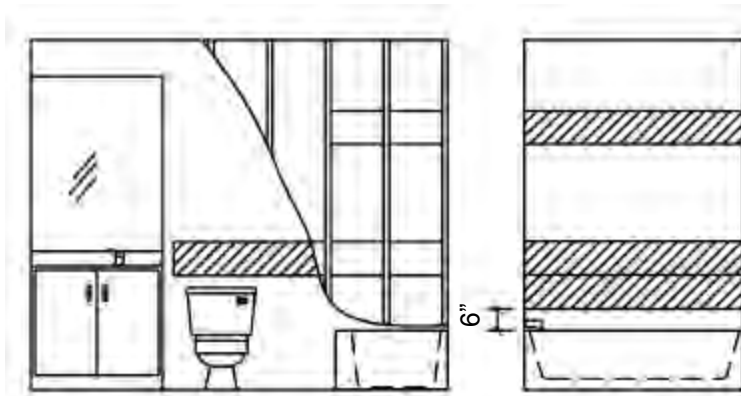

**Clear Opening at Doors**

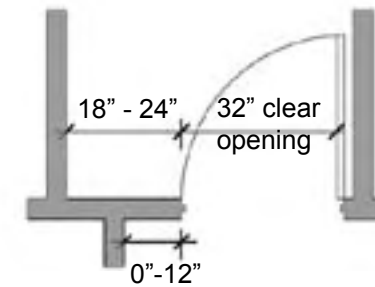
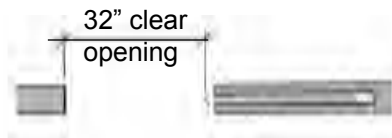

**Maneuvering Space at Doorways**

# HOME ENTRY

---

## Options

Home entrance is usually the most frustrating of problems for a person with a disability. A person may become disabled because of age, health issues, or accident and find that their home no longer meets their needs. However, modifications can often be made to allow a person to continue to use their home.

Modifying the home entry for accessibility usually involves three options; ramps, low rise steps, or lifts. Another alternative, if feasible, is a sloped pathway.

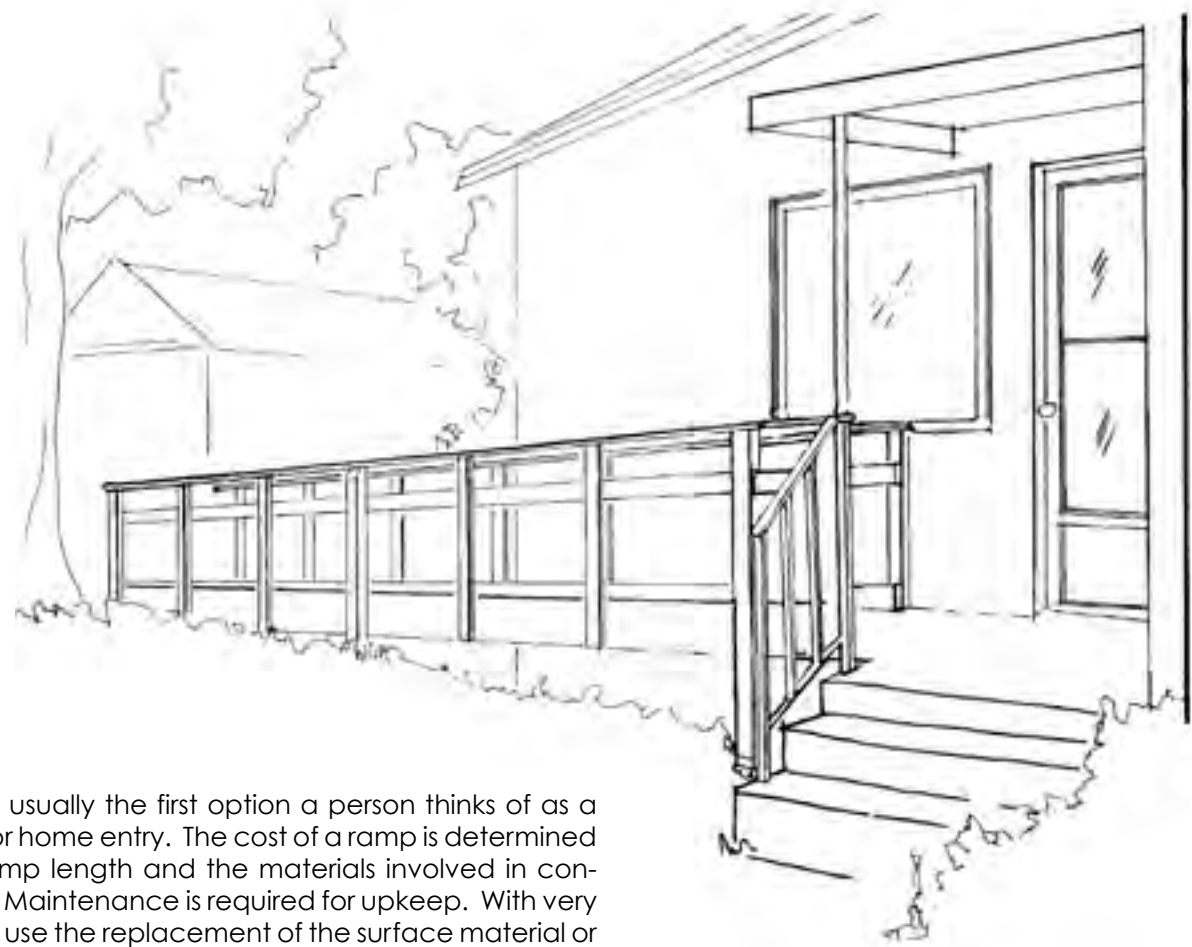

### Ramp

A ramp is usually the first option a person thinks of as a solution for home entry. The cost of a ramp is determined by the ramp length and the materials involved in construction. Maintenance is required for upkeep. With very long term use the replacement of the surface material or structural members may also be required.

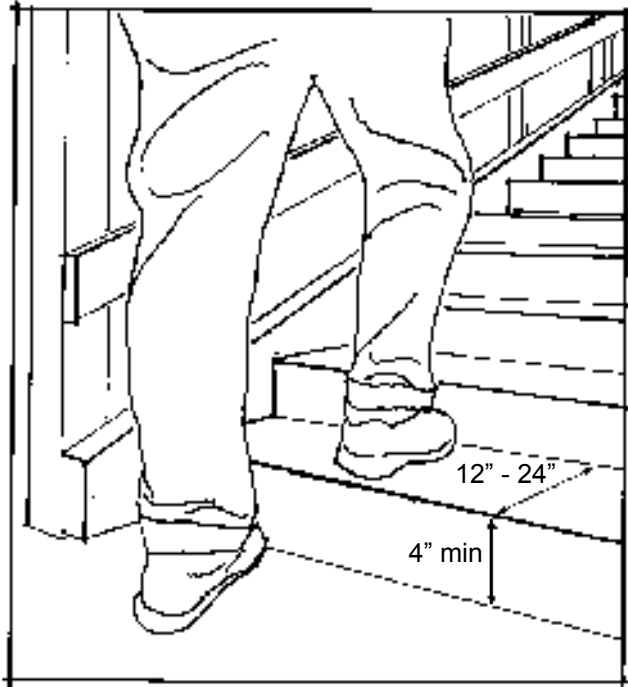

### Low Rise Steps

In some situations low rise steps are all a person needs to change levels. Well placed handrails and steps with a rise of 4 inches are easy to navigate. Deep treads are helpful for a person using a walker.



### Lift

When a ramp is not feasible, whether due to site considerations, ramp size, or user abilities, a vertical lift can provide a good solution. Space requirements are small and usually require a concrete slab and pathway. Controls can be modified to be fully automatic. A lift requires electrical power and needs periodic maintenance. An overhead cover is useful for weather protection but is not necessary as the lift is intended for exterior use.

---

## Typical Homes

### Contemporary

In contemporary homes a level entry can be incorporated into the overall design and provide an attractive entry. In this example a sloped pathway provides easy access to the front door and the landscaping is level with the pathway.



### Rambler

In general, rambler usually have less rise than other types of homes and a ramp may not be necessary. In this situation, a pathway was sloped up to the entry. The soil and sod were gently sloped at each side of the pathway for safety.



### Bungalow

Bungalows generally have high steps and small front and side yards. The back or side doors frequently have steps inside the dwelling which make it infeasible to put a ramp in the back or side yard. In this example, the ramp fits at the existing opening of the porch.





### **Mobile Home**

Many mobile homes have a 30 to 36 inch rise to the entrance. A ramp can often be built from a platform at one of the entries. This particular ramp is at the back entry of the dwelling. The driveway provides the landing at the end of the ramp.



### **Split Level**

A split-level home almost always requires a lift due to height considerations. Sometimes a lift can be installed in the garage with an opening cut in an existing wall for entrance. More frequently, lifts are installed near a back deck and have a pathway from the front of the home or driveway. If there is a step from the deck to the door threshold, modifications to the deck or threshold are necessary.



### **Two Story**

Older homes can often be difficult to make accessible. In this particular two story home the yard was small and had an abrupt rise where the existing pathway and public sidewalk met. The solution required building up the existing porch with a platform, adding another pathway, and providing a porch lift. The lift was accommodated by cutting through the porch wall. Happily, the lift was also under the existing porch overhang.



# RAMP PLANNING

---

In ramp planning there are a number of functional considerations related to the location and size of a ramp.

Assessment of the entrances to the home is the first step in planning for a ramp. Look at each entrance carefully including the garage or carport entrance. Each entrance is different with unique factors to consider. One entrance will often work better than another.

## Rise at Each Entry

The rise is the difference between the door threshold and the ground below. For each inch of rise plan for one foot of ramp. The higher the rise, the longer the ramp.

## Clear Width of the Exterior Door Opening

This is the measurement from the doorstop molding to the inside edge of the door in an opened position. A 2'-8" minimum clear opening is desirable. With standard hinges, a 3'-0" wide door is necessary to achieve a 2'-8" clear opening. A smaller opening may work, but should be verified with the needs of the individual user.

## Weather Exposure

A northern exposure can be a problem in the winter due to ice and snow.

A roof dripping on a ramp can increase the ice hazard in winter as well as make it slick in rainy weather. The addition of gutters and downspouts can often eliminate or minimize this hazard.

Planning a ramp under a carport or in a garage provides weather protection and minimizes maintenance.

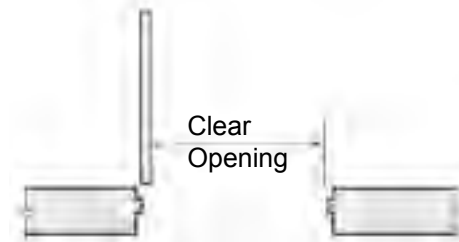
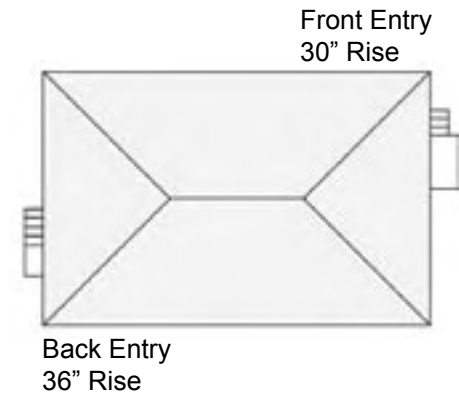

## Site Considerations

When planning for a ramp the following things on the site need to be taken into consideration.

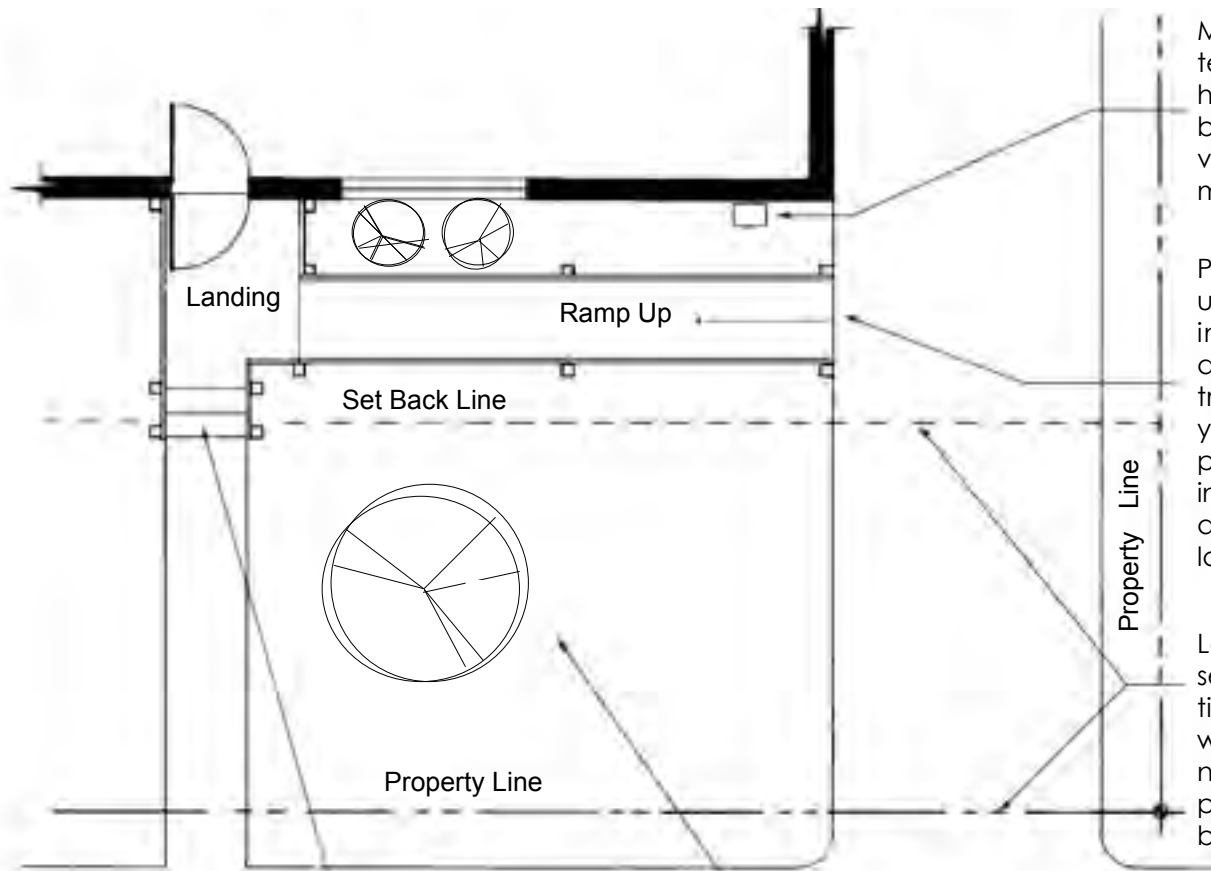

Maintain access to gas meters, water shut off valves, sewer clean-outs, hose-bibs, telephone and electrical boxes, sprinklers, and crawl space vents or window egress from a basement.

Proximity to vehicle drop off/pick up needs to be taken into account in relation to convenience and accessibility. Consider the normal traffic patterns to entrances and yard. Note trees, shrubs, and other plantings as well as grade changes in the yard. In this particular case, the driveway also serves as the bottom landing.

Locate property lines and zoning setbacks to define limits of potential structures. Verify property lines with local zoning department and neighbors. If other options are not possible, variances can sometimes be obtained from local officials.

Maintain pedestrian access route whenever possible.

Locate a ramp to maintain maximum use of the yard for mowing, weeding, moving garbage cans, or playing.

## Measuring the Rise

Calculating the rise is an important step in planning for a ramp. This calculation needs to be done with accurate measurements. It can be tempting to estimate the length, slope, and location of a ramp; however, this may create more problems than it solves. If a ramp is too steep, it can be hard for someone in a wheelchair to navigate the slope and can cause loss of control in descent. Even pushing a person in a wheelchair up a slope that is too steep may be difficult and unsafe. If a person with a walker cannot navigate steps, the slope on a ramp may need to be even gentler than for a person in a wheelchair. Too steep a slope can force a person using a walker to lean at an uncomfortable angle which can cause the person to become unsteady.

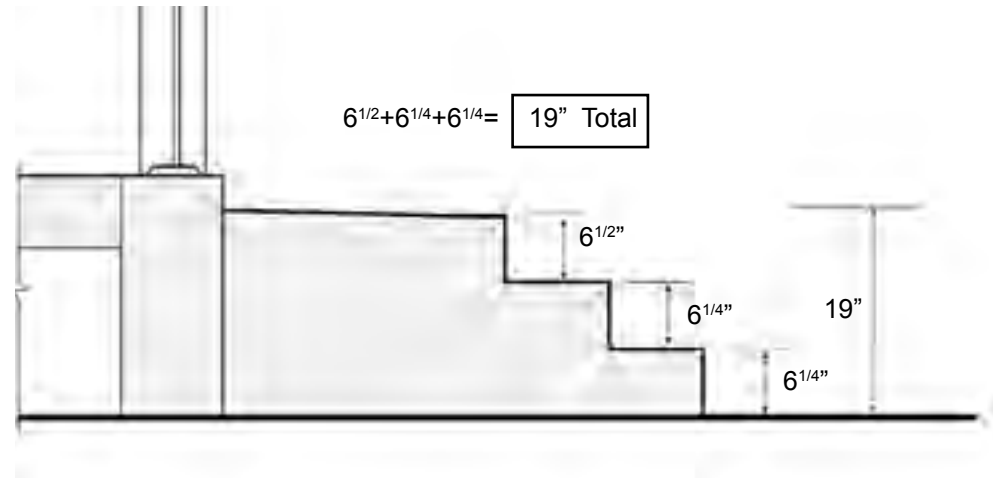

### Measuring the Rise of Existing Stairs

The first step in determining the total rise involves measuring the height of each individual step. In some homes, the variation between steps may vary as much as 1/4 to 1 inch. The total stair rise can be confirmed by measuring from the top of the porch to the sidewalk or ground.

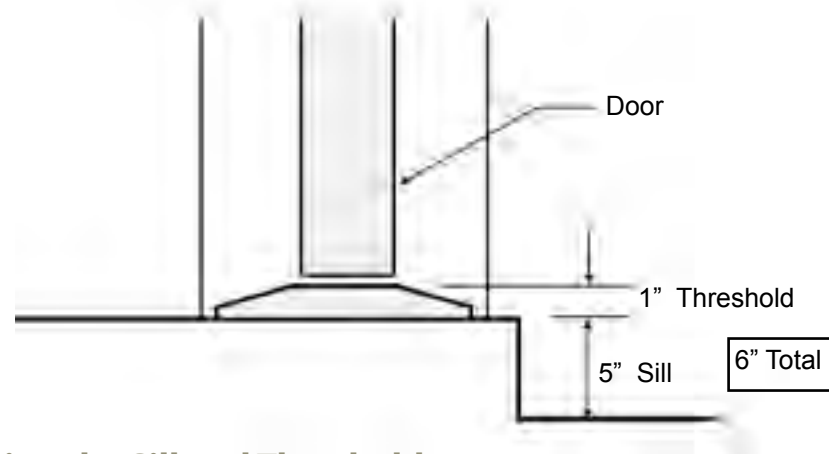

### Measuring the Sill and Threshold

Measurement of the height of the sill and the threshold at the door entry also needs to be included in the calculations.

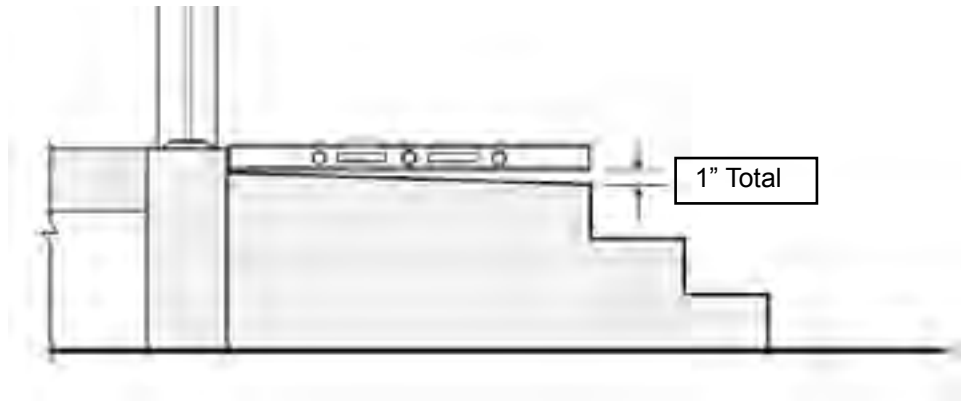

### Measuring the Porch Slope

It is also important to measure the slope on the porch in determining the total rise. A four foot level is a helpful tool for accomplishing this task.

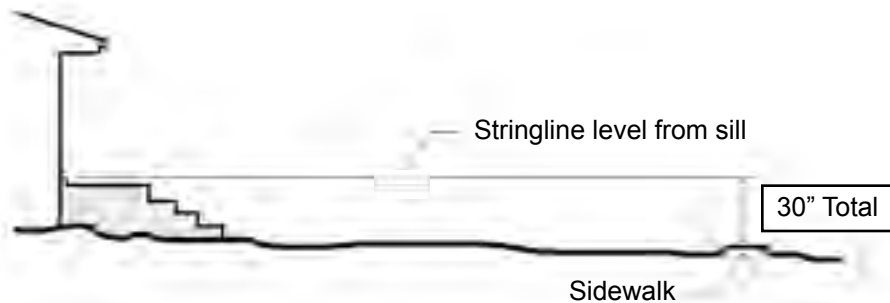

### Measuring the Rise from an Existing Sidewalk

In many situations the ground is uneven or is sloped away from the porch. The degree of this grade change may seem insignificant to the eye, but can add additional inches to the rise. Remember, even though it may be only a few inches, this translates into additional feet in ramp length. A string level, available at most hardware stores, is a helpful tool for measuring this grade change if a builder's level is not available.

## Determining Ramp Length

After each of the measurements is taken and double checked to verify accuracy, the total is calculated to get the total rise. In the example shown, subtracting the porch rise from the total rise leaves 4 inches of site slope. Once the site rise is determined and included in the total calculation, the length of the ramp can be determined.

|                          |   |        |
|--------------------------|---|--------|
| Steps (total)            | = | 19"    |
| Sill & Threshold (total) | = | 6"     |
| Porch Slope (total)      | = | 1"     |
| <hr/>                    |   |        |
| Porch Rise               | = | 26"    |
| Site Slope               | = | 4"     |
| Total Rise               | = | 30"    |
| <br>                     |   |        |
| Total Ramp Length        | = | 30'-0" |

Remember, local building codes and accessibility standards require one foot of ramp for one inch of rise (8.3% slope or 1 in 12). This means that a total rise of 30 inches will require at least 30 feet of ramp. Any platforms and landings also need to be added to this dimension. This usually is much more ramp than most people visualize.

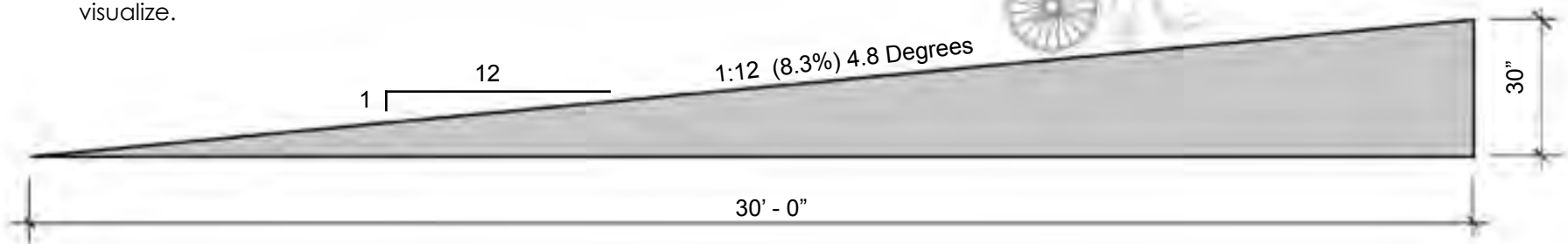

# Measuring the Site

Once the entrance is determined and the total rise is calculated, the house, yard, sidewalks, and landscape elements need to be measured and located.

Sketch the building and the surrounding site. Measure the house, windows, window wells, doors, porches, stairs, and driveway.

Locate property lines, sprinklers, utility meters, hose bibs, trees and plants, and other relevant information. Also, measure roof overhangs and downspouts. Note which direction is North on the site plan. Make several copies for drawing possible ramp configurations.

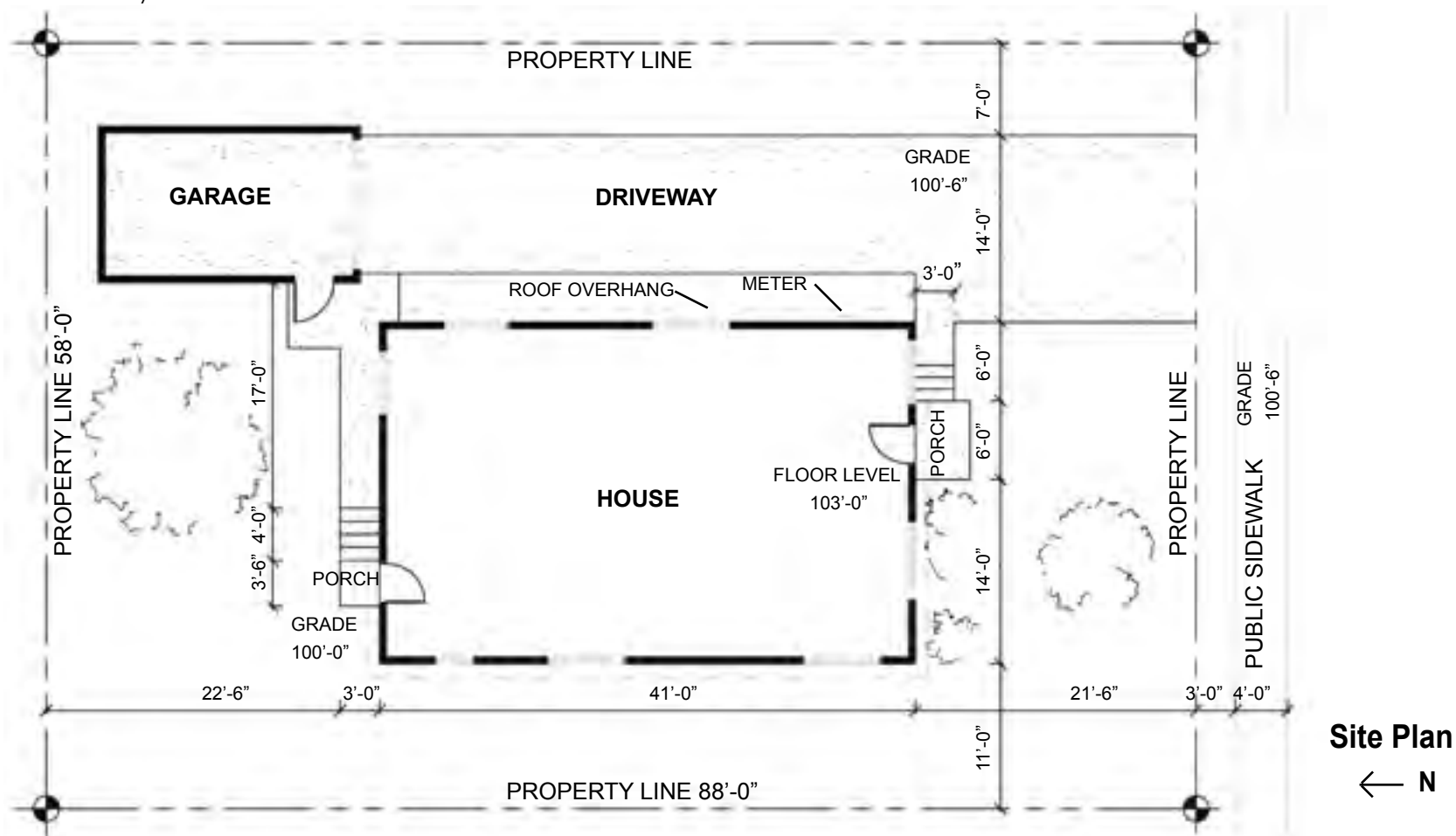

---

## Ramp Configurations

Once the site has been measured, ramp configurations need to be considered. There are three typical ramp types: straight ramps, 90 degree ramps, and switchback ramps. For safety, ramps must have flat landings at doorways and at points where the ramp switches direction. It is very difficult to open a door using a wheelchair or a walker while positioned at an angled slope on a ramp.

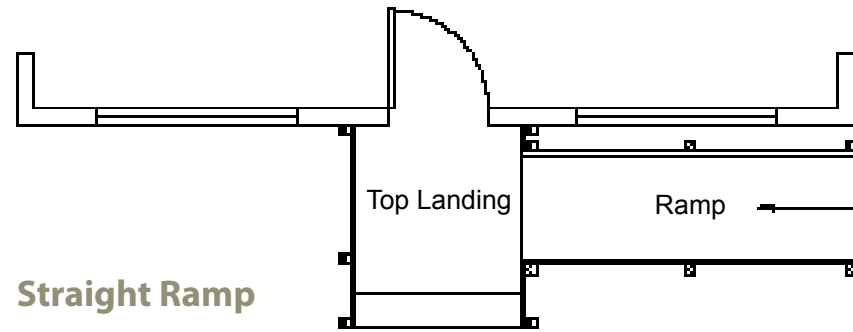

**Straight Ramp**

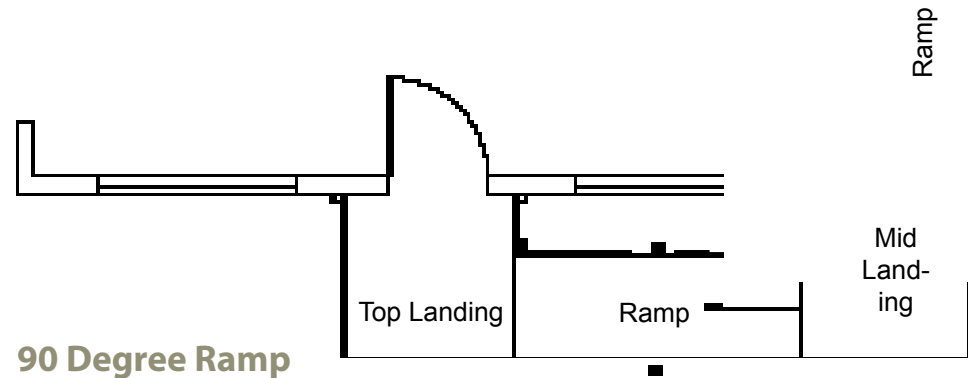

**90 Degree Ramp**

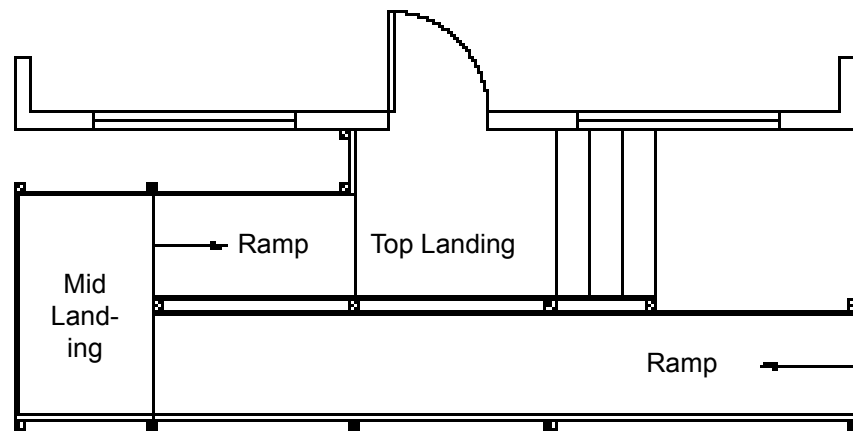

**Switchback Ramp**

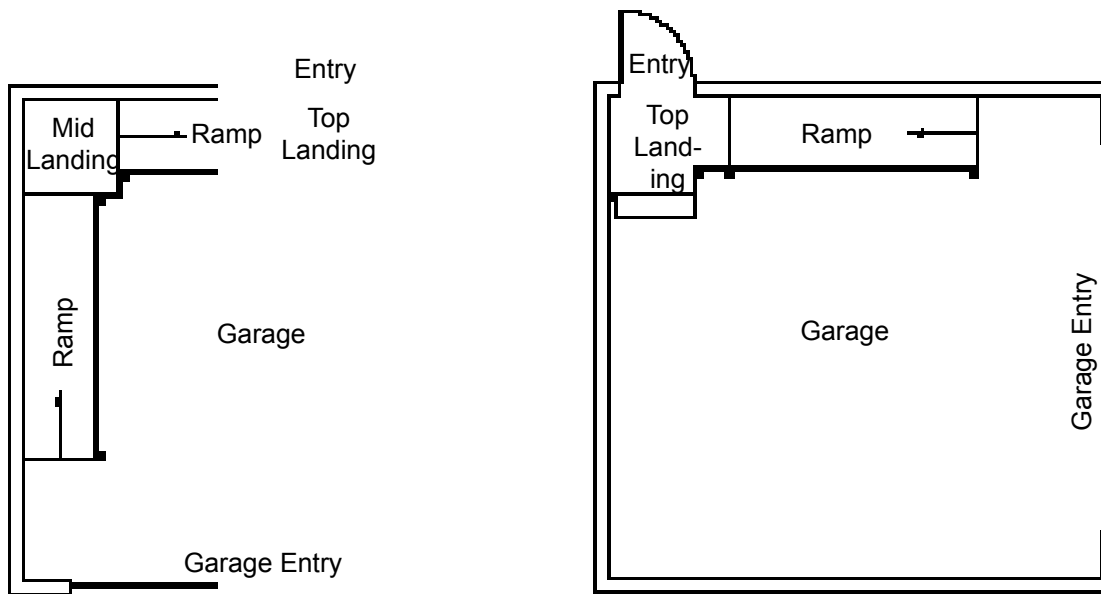

### Ramp in a Garage

A ramp in the garage is very advantageous. Not only is it close to the vehicle drop off, it is also protected from the weather. These are typical ramp layouts in a garage. A 90 degree ramp can achieve longer distances and accommodate a higher rise. The straight ramp works with a shorter rise. In each situation space is allowed for one car. When planning for a ramp in a garage, be sure to allow room for an access aisle from the vehicle to the ramp.

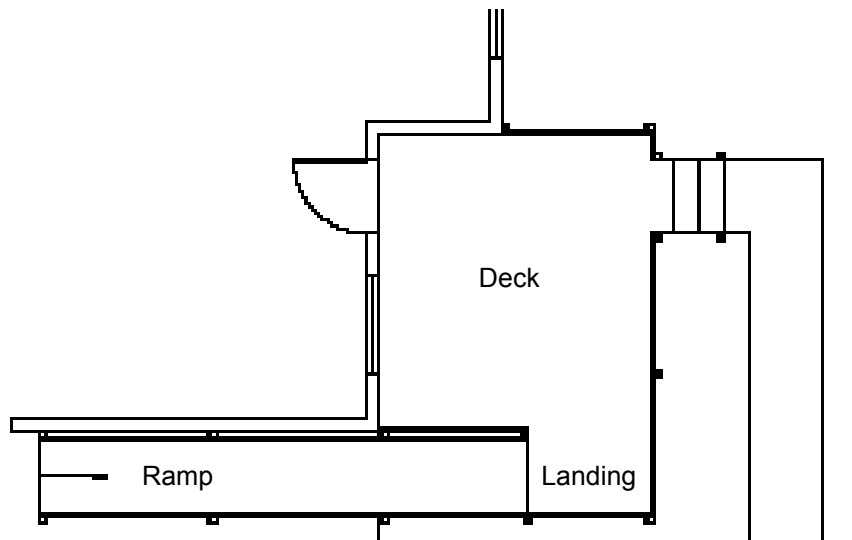

### Deck with Ramp

Integrating a ramp with a deck is another option. If designed well it can provide an attractive way onto the deck for everyone.



## Laying Out Ramp Options

Once the site plan is drawn, use copies or tracing paper to sketch possible ramp configurations. Remember to allow at least one foot of ramp for each inch of rise.

At this point, referencing the **Standard Dimensions** section for a more complete understanding of typical ramp elements and their dimensions may be helpful.

In this example the rise is large and yard space is limited. The back door rise is higher, has a northern exposure, and does not have a convenient accessible route into the home. With these site considerations, the ramp will work best at the front.

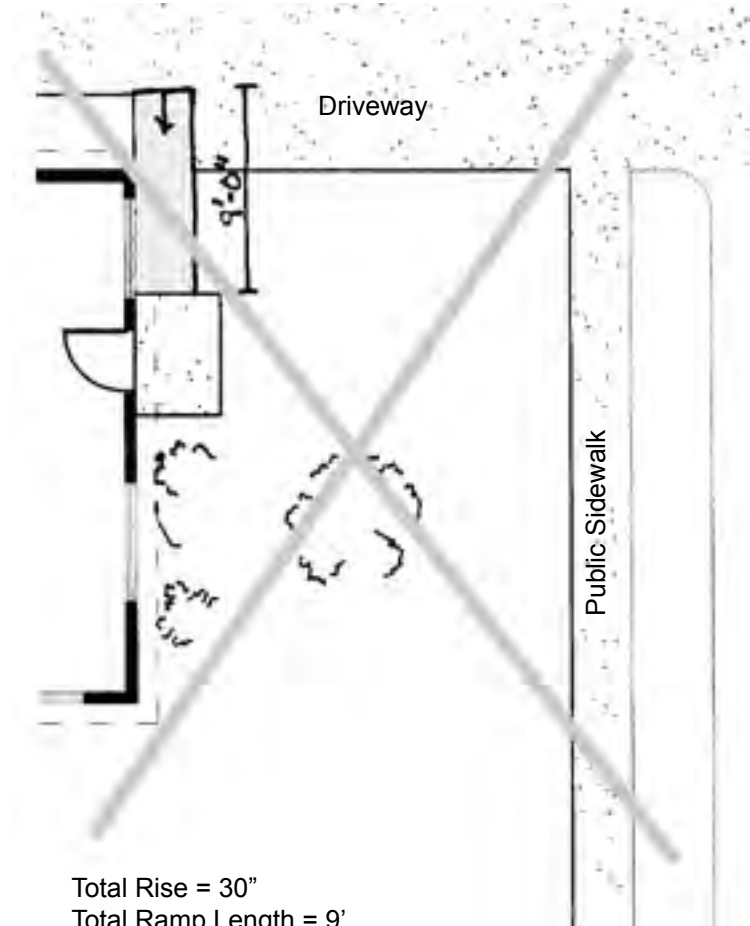

\*Level Site

### Option A

This is usually the first layout considered - a straight run. In many instances it will work. However, in this situation the distance from the porch to the driveway only allows a 9 foot ramp. With a 30" rise, this would make the ramp much too steep and unsafe.

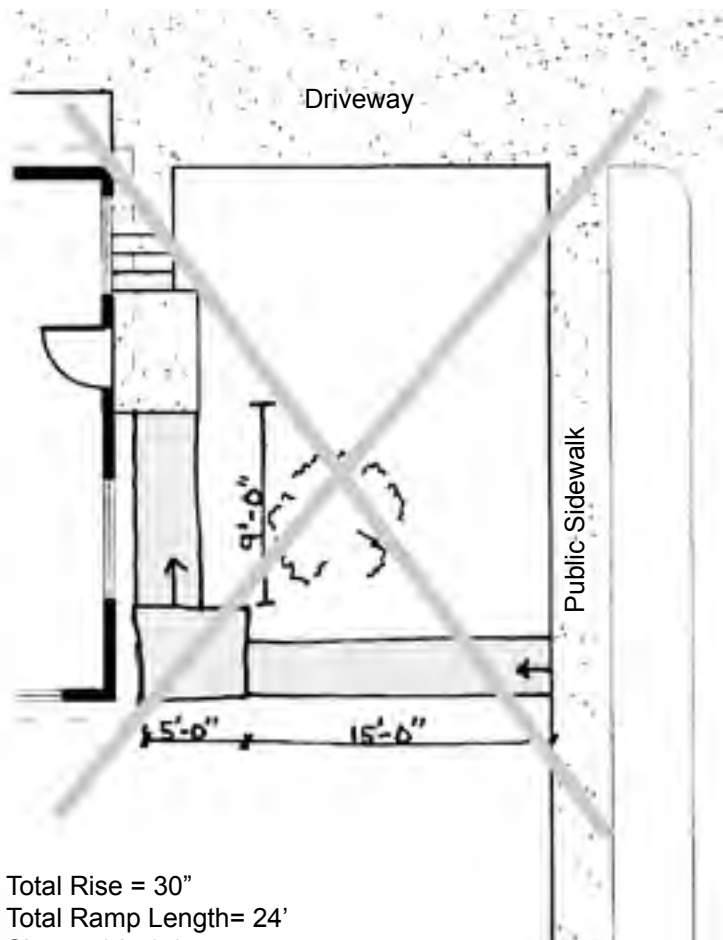

Total Rise = 30"  
 Total Ramp Length= 24'  
 Slope= 1 in 9.6

\*Level Site

### Option B

This option uses a 90 degree layout along the front and side of the yard. With a 5 foot intermediate landing, and using the public sidewalk as the bottom landing, the total ramp length is 24 feet. Again, this does not work, because the ramp is too short and the slope is too steep.

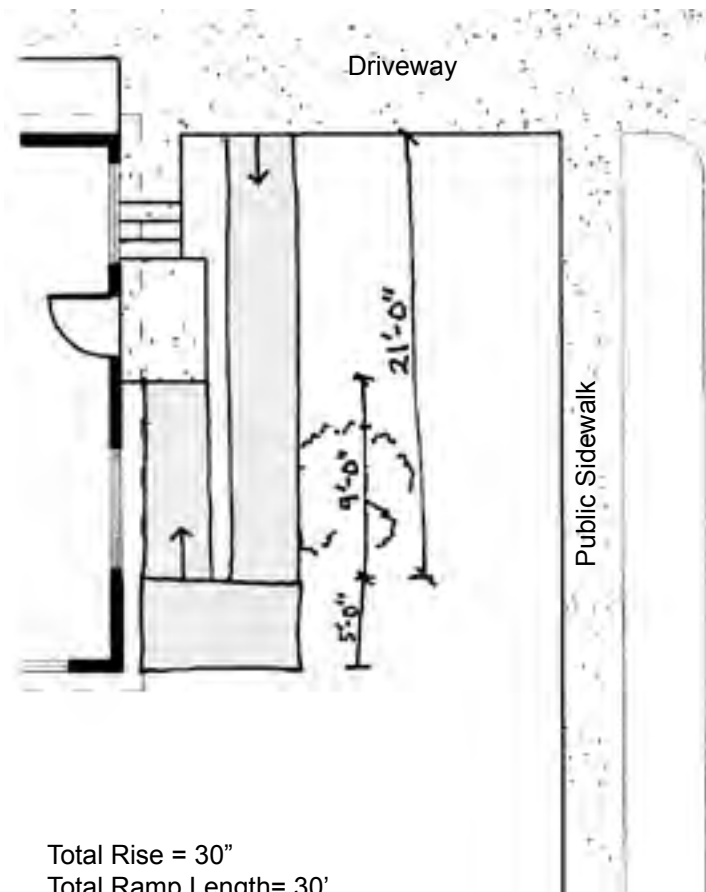

Total Rise = 30"  
 Total Ramp Length= 30'  
 Slope= 1 in 12

\*Level Site

### Option C

This option is the only one that provides the 1:12 slope. The ramp itself is 30 feet long. It uses the driveway as a landing instead of having to add a 5'-0" landing at the bottom of the ramp.

# WOOD RAMP CONSTRUCTION

---

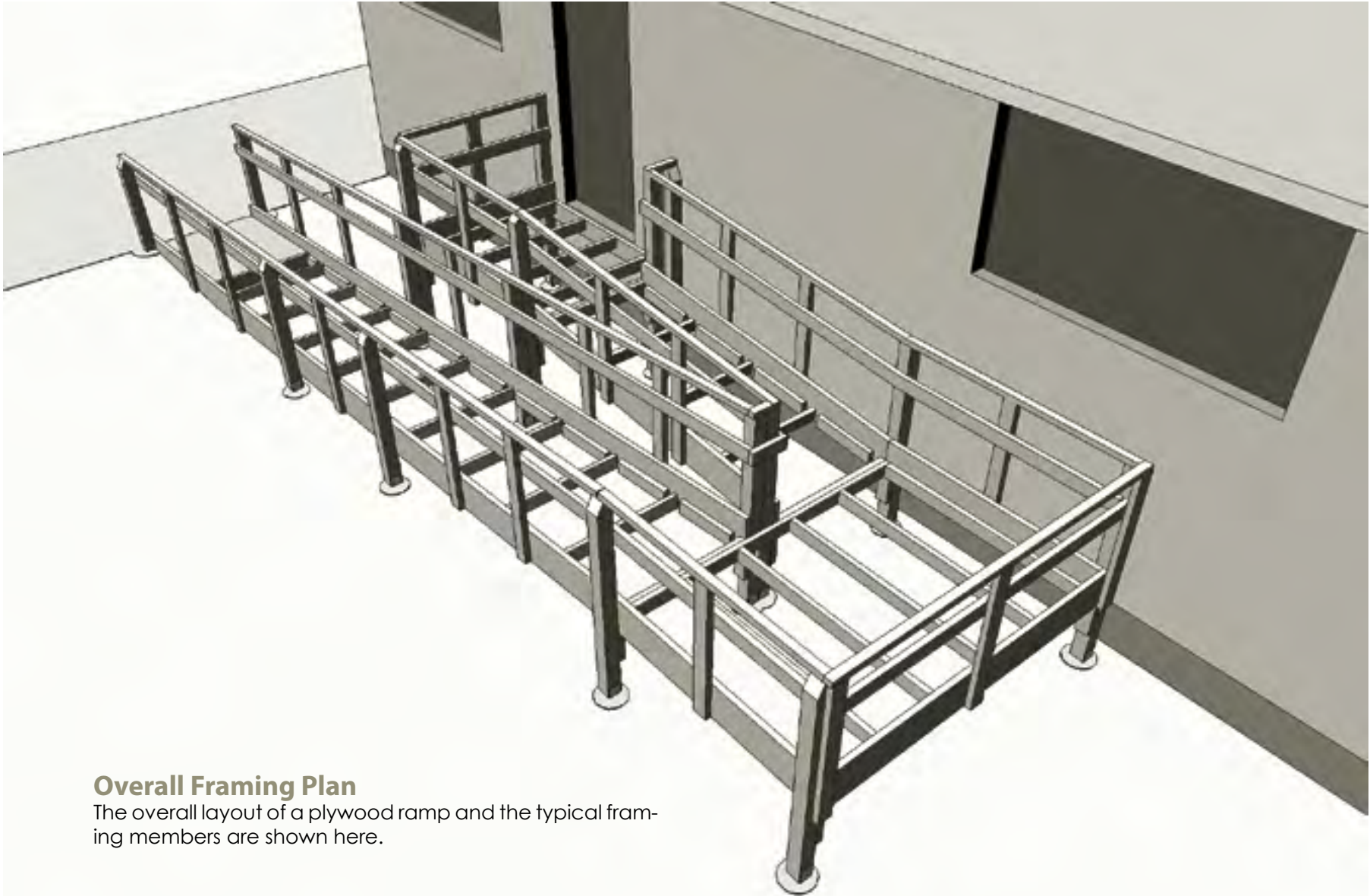

## **Overall Framing Plan**

The overall layout of a plywood ramp and the typical framing members are shown here.

## Ramp Section

This cross section shows the foundation and framing members and their relationship to each other in more detail. Generally, ramps are framed with 4 x 4 treated wood posts, 2 x 10 stringers, 2 x 4 joists @ 16 inches on center, 3/4 inch plywood decking, and 2 x 4 handrail supports.

3/4" pressure treated or marine plywood

2 x 4 nailers attached between joists with grabber screws @ 8" on center

2 x 4 bearing blocks bolted with 1/2" diameter thru bolts or lag bolts

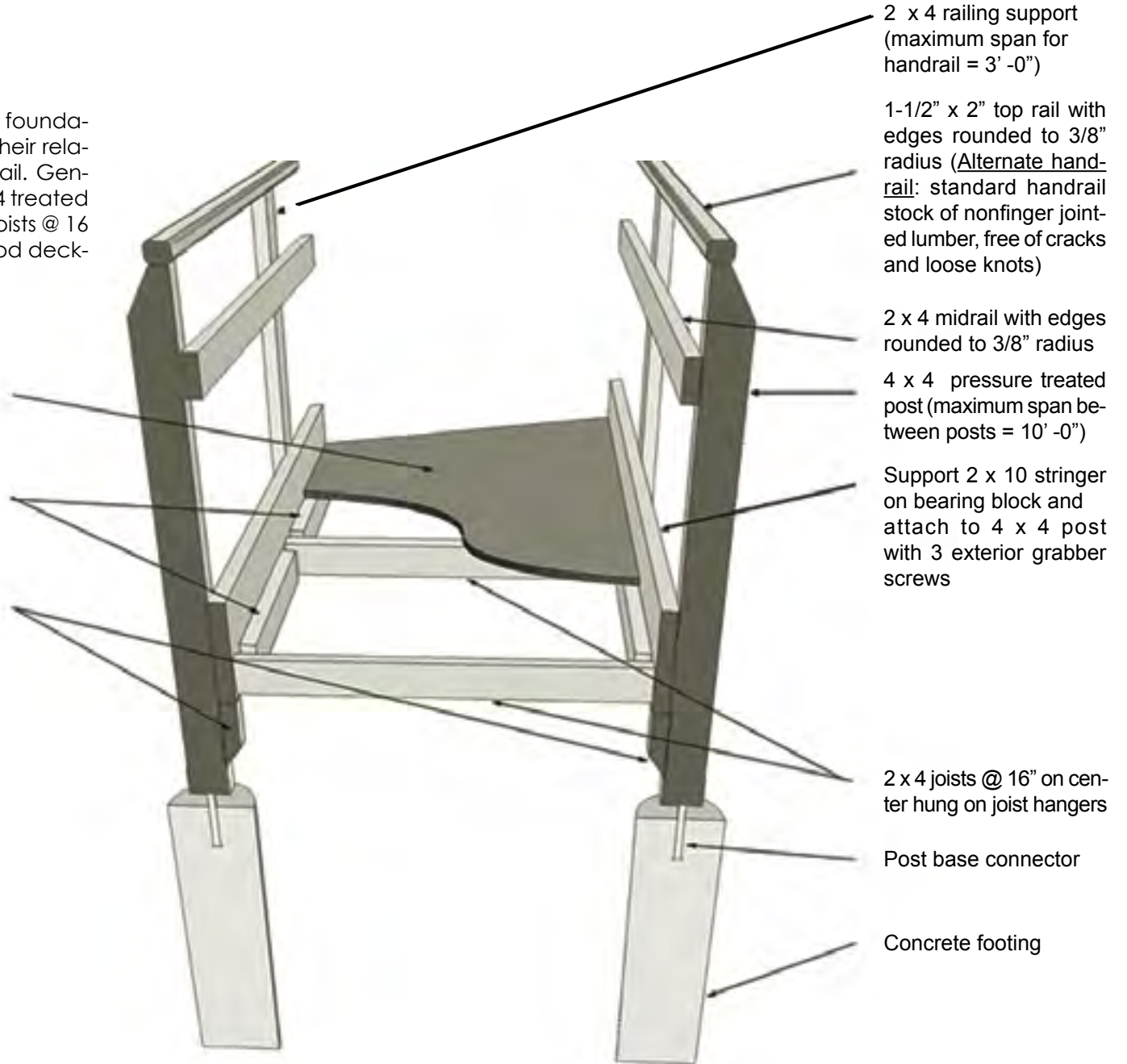

2 x 4 railing support (maximum span for handrail = 3' -0")

1-1/2" x 2" top rail with edges rounded to 3/8" radius (Alternate handrail: standard handrail stock of nonfinger jointed lumber, free of cracks and loose knots)

2 x 4 midrail with edges rounded to 3/8" radius

4 x 4 pressure treated post (maximum span between posts = 10' -0")

Support 2 x 10 stringer on bearing block and attach to 4 x 4 post with 3 exterior grabber screws

2 x 4 joists @ 16" on center hung on joist hangers

Post base connector

Concrete footing

# Structural Supports

These drawings show in detail how the different framing members of a plywood ramp are joined.

## Bearing Block

Of special note in this drawing is the bearing block detail. The bearing block is for support where the ends of the stringers come together. It is important to plan the length of the stringers so they meet at the posts. The bearing blocks then provide the continuity of support necessary.

## Nailers

This section details the 2 x 4 nailer which is screwed to the 2 x 10 stringer. The nailer allows support for the 3/4" plywood decking.

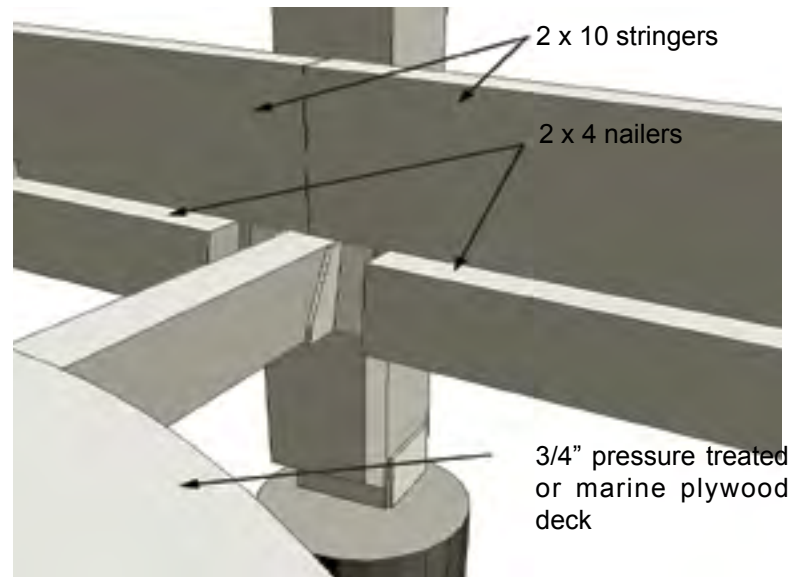
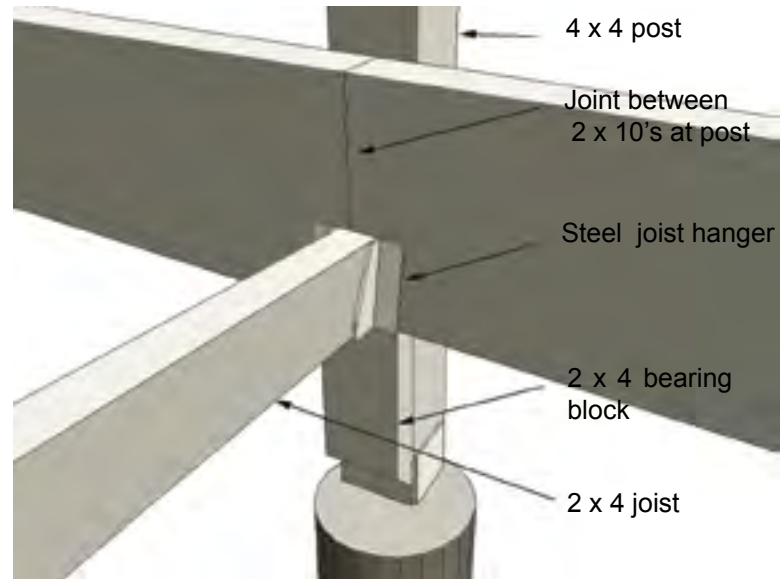

# Handrails

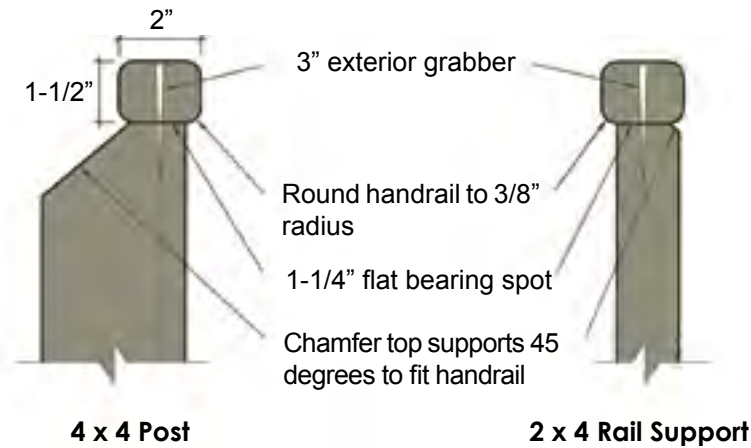

## Handrails

Handrails require careful detailing to function safely and serve the user well. Typical details are shown here. It is helpful at this point to relate back to the overall framing plan to understand the coordination of the details with the overall design.

Codes in some areas may require using 1-1/4 to 1-1/2" wide handrails. If so, an alternative to the 2" wide rail shown is to use 1-1/2" diameter, 3/4 round non-finger jointed, knot free, wood handrail material. Handrails can be mounted on 4x4 posts or rail supports.

Handrails are required by code on all ramps higher than 6". They are not required on sloped pathways that have a slope of 1:20 or gentler.

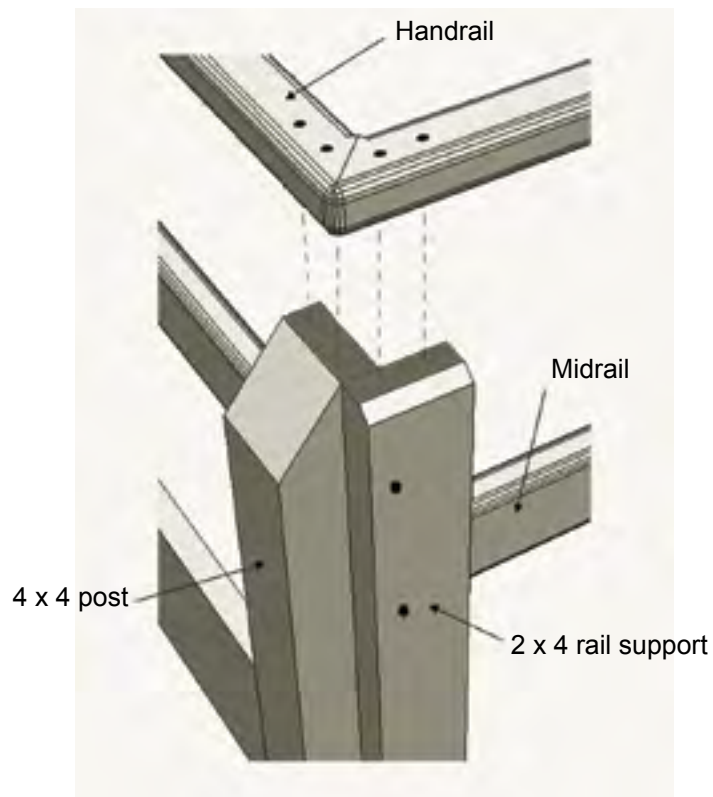

## Corner Detail

Of special note is the detail of the handrail at the corner of the ramp platform. This detail allows for a continuous and smooth handrail at a 90 degree corner with adequate rail support in both directions.

# Footings

The details presented here are examples that have been developed for the construction of a basic wood ramp. Wood ramps are usually cost effective and the construction is within the ability of anyone with basic construction skills. A disadvantage of a wood ramp is that the materials do deteriorate over time. It is recommended that the deck, handrails, posts, and wood joists of the ramp be checked regularly for structural stability.

These details are presented as typical examples and do not apply to every situation. The details may require some adaptation to each individual situation.

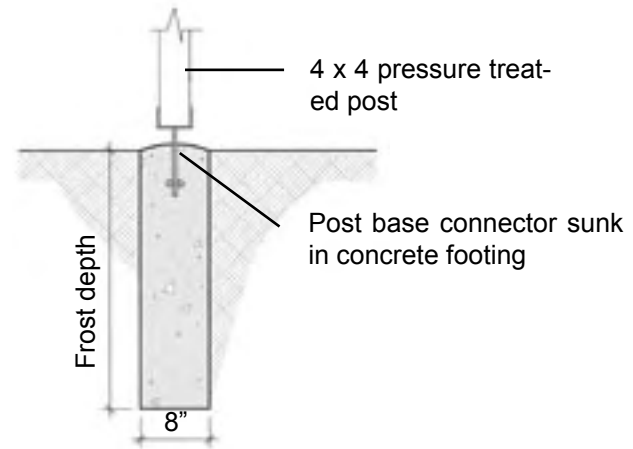

## Concrete Footing

This detail can be used at most locations, except at the two beginning posts of the ramp. For rigidity, the beginning posts at the base of the ramp need to be sunk in the ground as pictured below. The footing should be placed at a minimum depth of 2'-6"; adjusted to the frost depth required in the area. Confirm with the local building official.

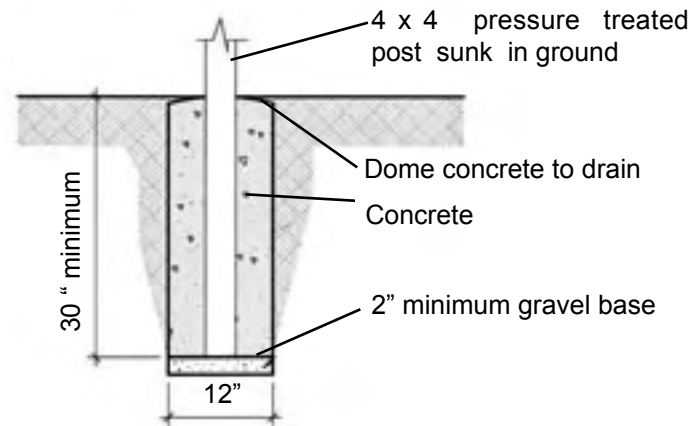

## Sunken Post

This detail is for use at the beginning posts at the base of the ramp. It is sunk in the ground to provide rigidity for the handrails. It is also an option for other posts in the ramp construction. The post should be placed a minimum depth of 2'-6"; deeper if frost depth in the area requires it. This can be confirmed with the local building official.

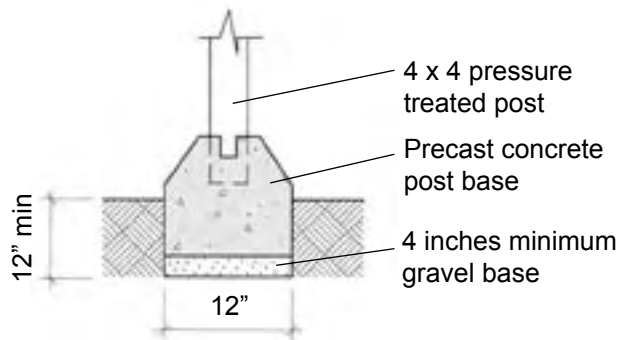

### Precast Pier

This is an alternate detail that is sometimes used in place of the concrete footing detail.

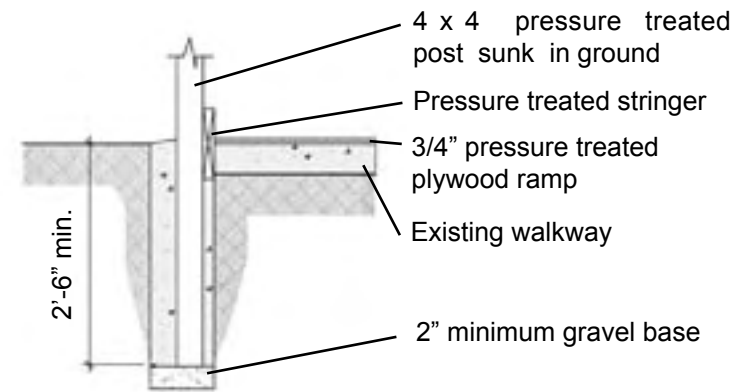

### Post Next to Walkway

This is an alternate detail for the post footing when building a ramp over an existing walkway.

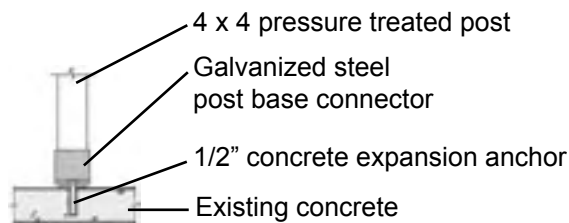

### Slab On Grade

This detail can be used for ramps built on a driveway, in a garage, or concrete sidewalk where the post would be on an existing slab. This detail is appropriate for all posts except the posts at the beginning of the ramp.

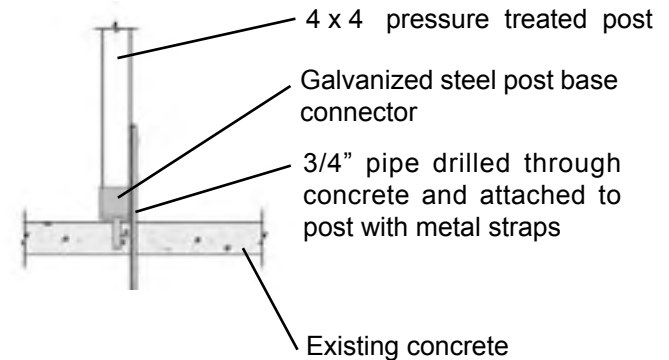

### Beginning Post On Slab

This detail is appropriate for the beginning post of a ramp built on an existing slab of concrete, such as a driveway, garage, or walkway. The pipe provides the necessary rigidity at the beginning of a ramp.



# Wood Ramp Cross Sections

## Ramp with Plywood

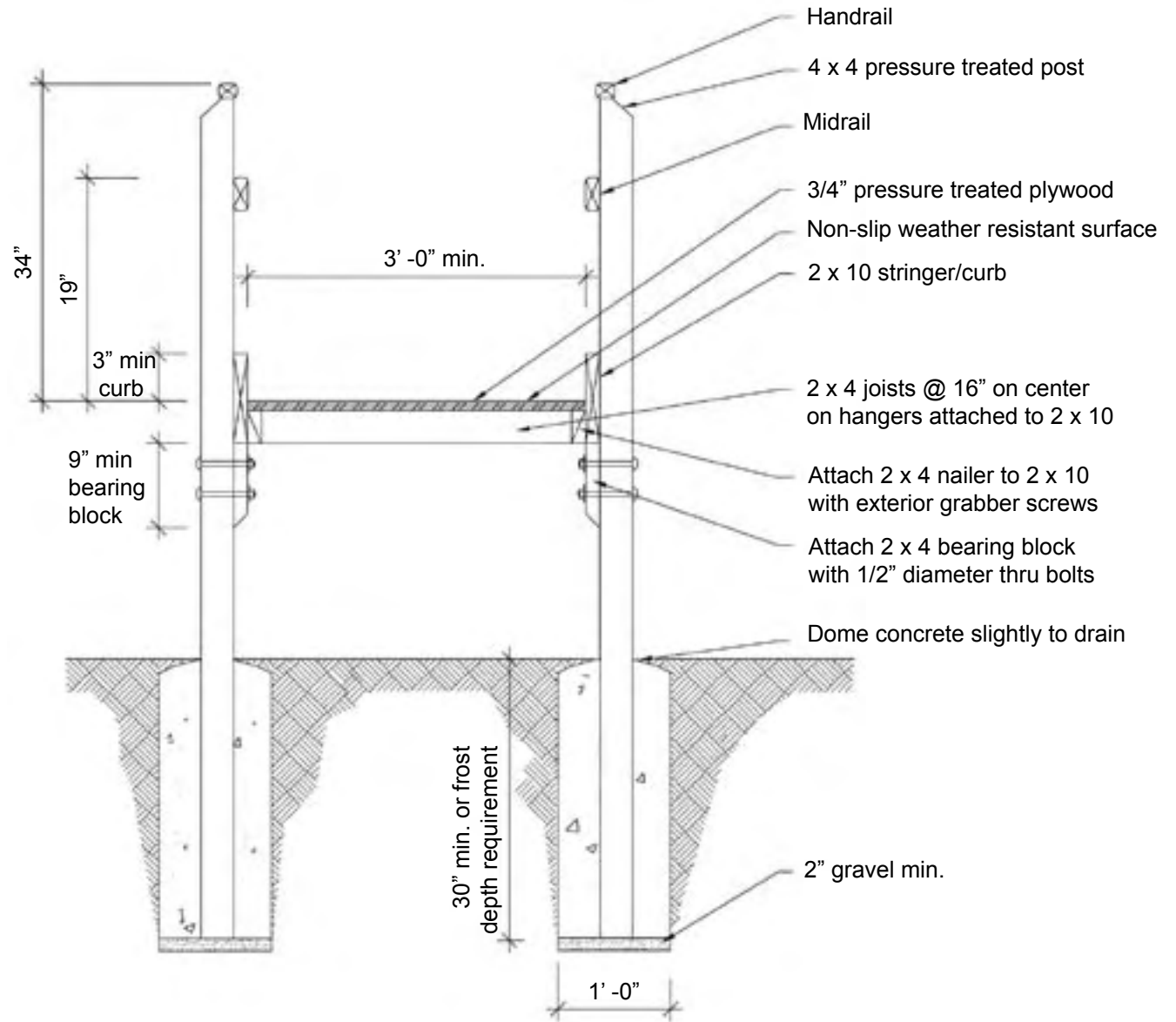

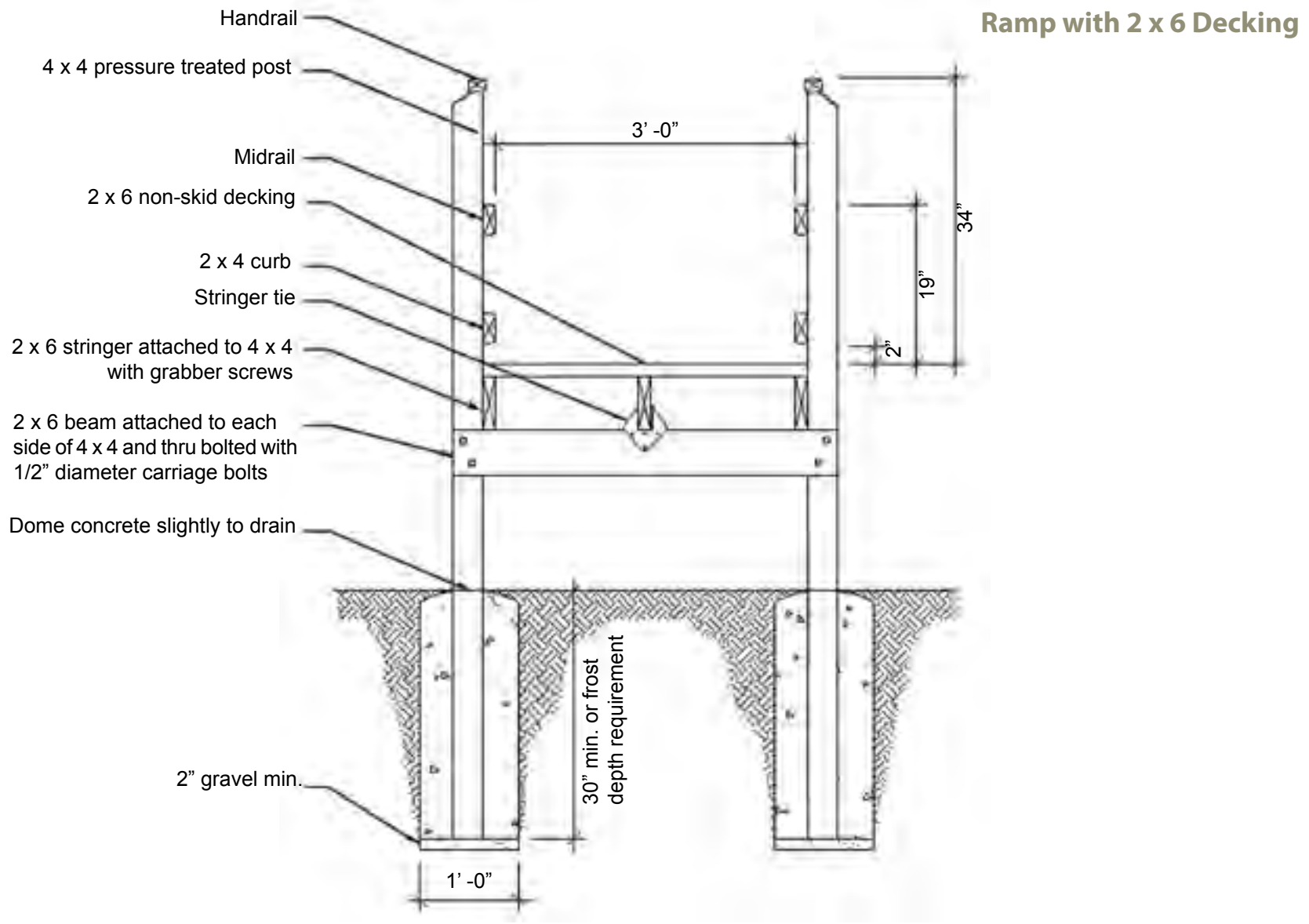

# Transitions - New Concrete

The transition to grade at the base of the ramp depends on the situation. The two transitions most often used are concrete or a metal plate.

The 2003 International Building Code (IBC) and most guidelines require 12" handrail extensions beyond the top and bottom of stairs and ramps. Exceptions may be made for dwelling units where handrails are not required to extend beyond the top and bottom of ramps. Verify with local building officials.

## Transition to New Concrete for Plywood Ramp

This option is used in most situations where the ramp does not land on existing concrete. The end posts are sunk in concrete in the ground for support. If a ramp approaches a public sidewalk, a 5 foot level landing usually needs to be provided beyond the sloped transition section. Some times a municipality will allow the public sidewalk to count as part of this landing but this needs to be verified with the municipality involved before construction.

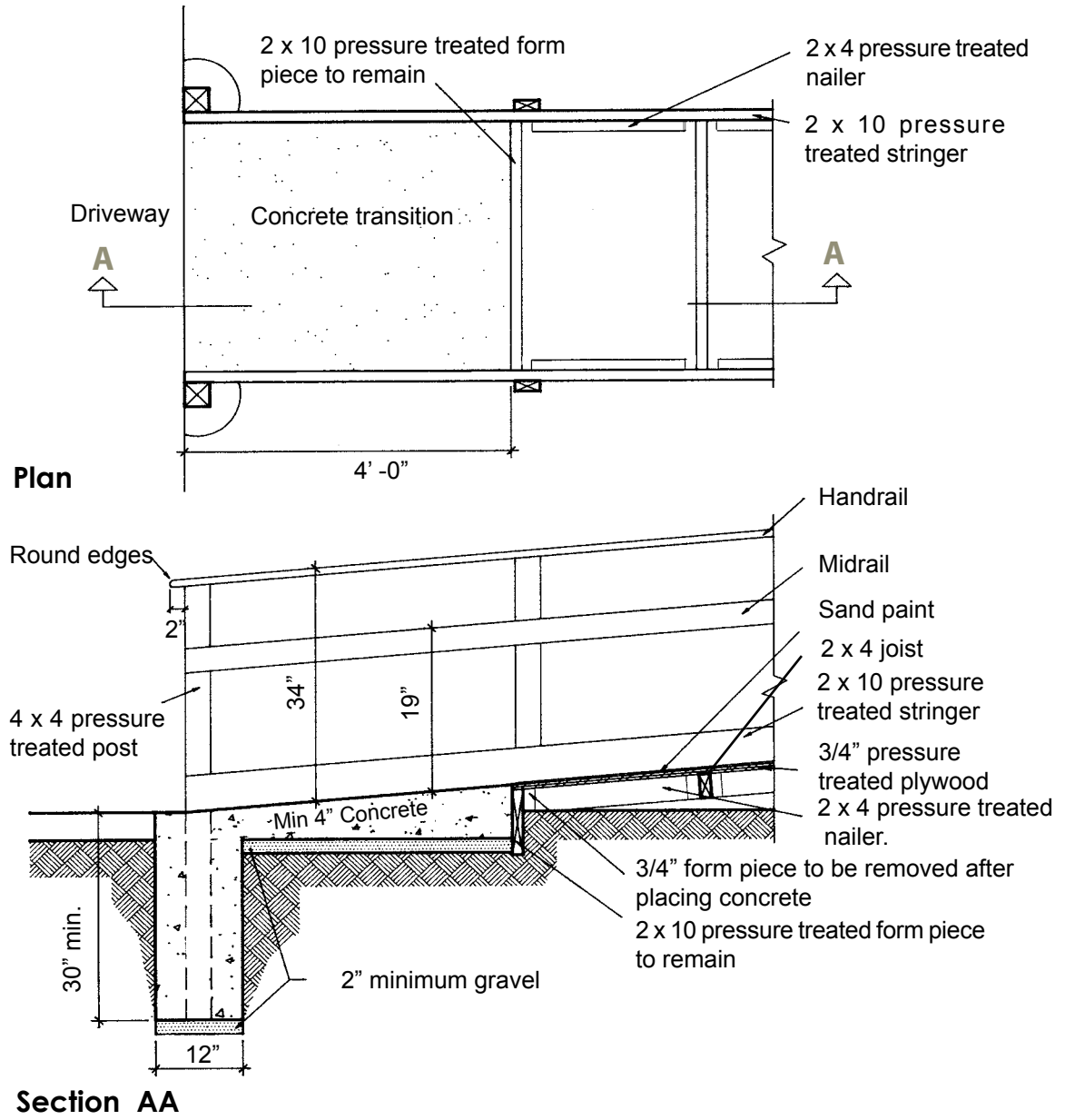

## Transition to New Concrete for 2 x 6 Decking

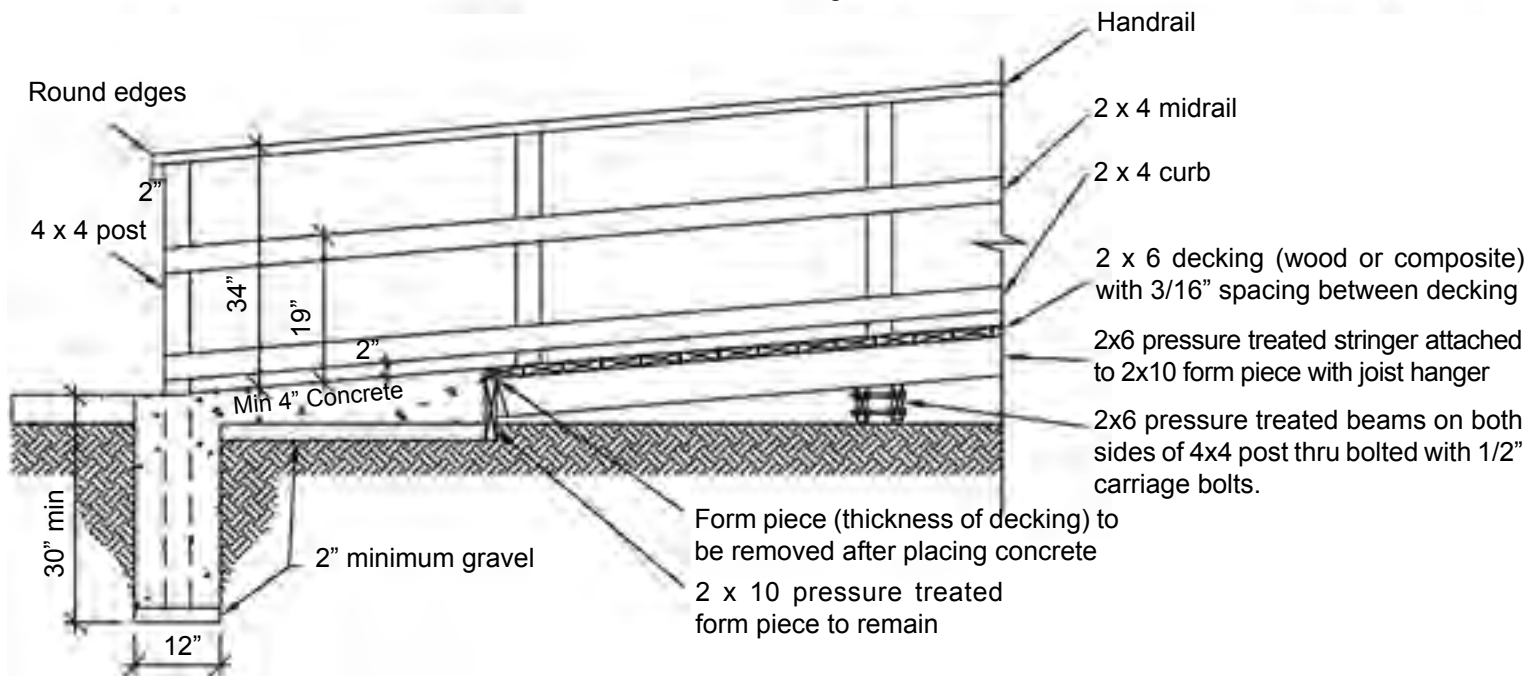
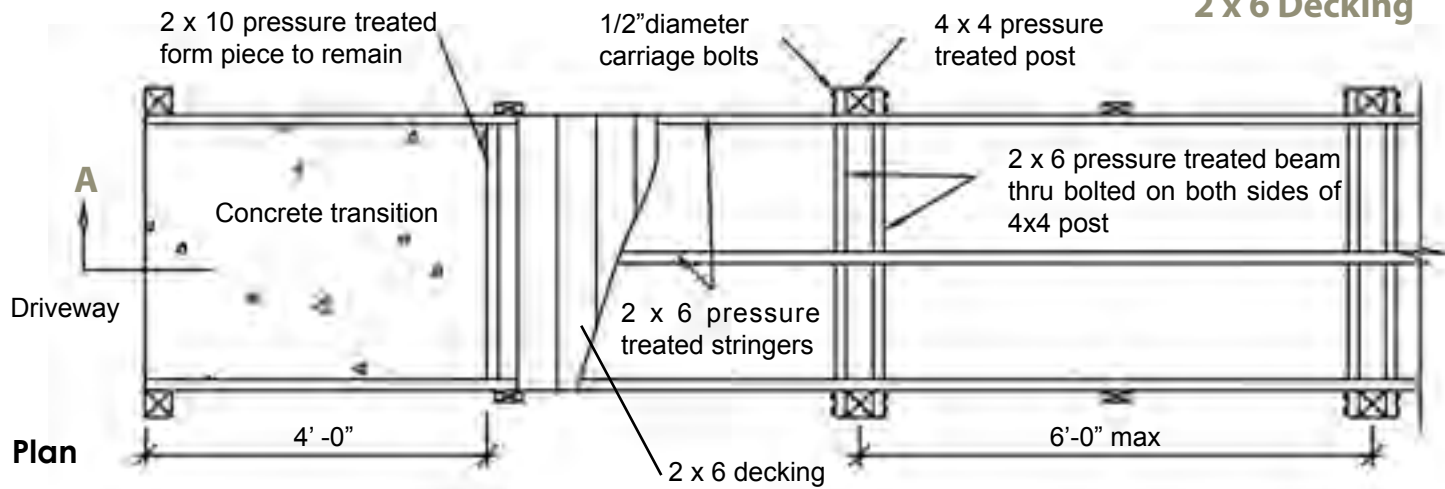

## Transition to Existing Concrete for Plywood Ramp

This transition section is used when the ramp bottom lands on an existing slab of concrete.

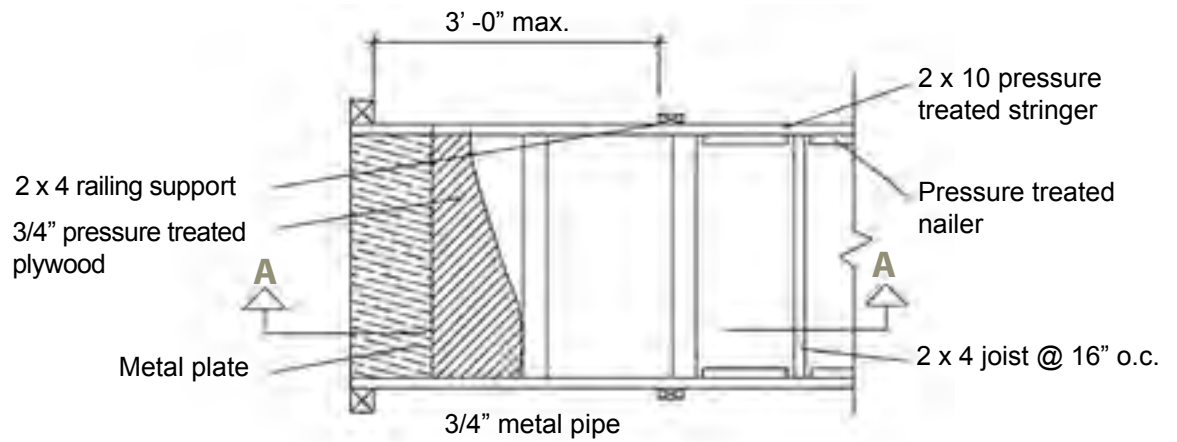

### Plan

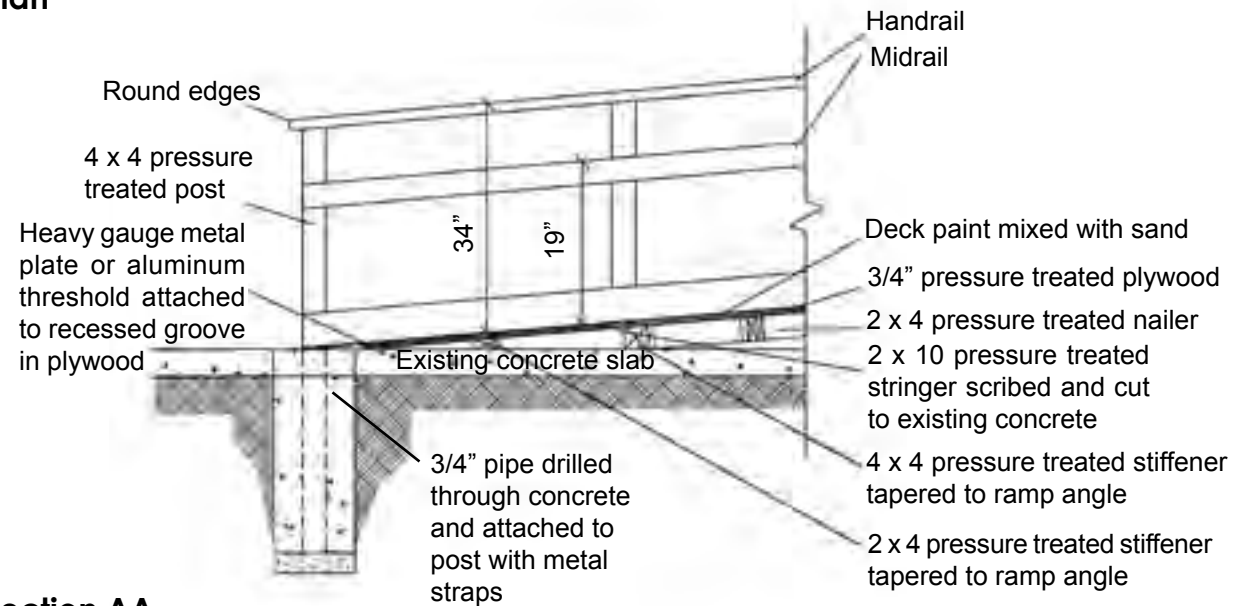

### Section AA

## Transition to Existing Concrete for 2 x 6 Decking

This transition section is used when the bottom of the ramp lands on an existing slab of concrete.

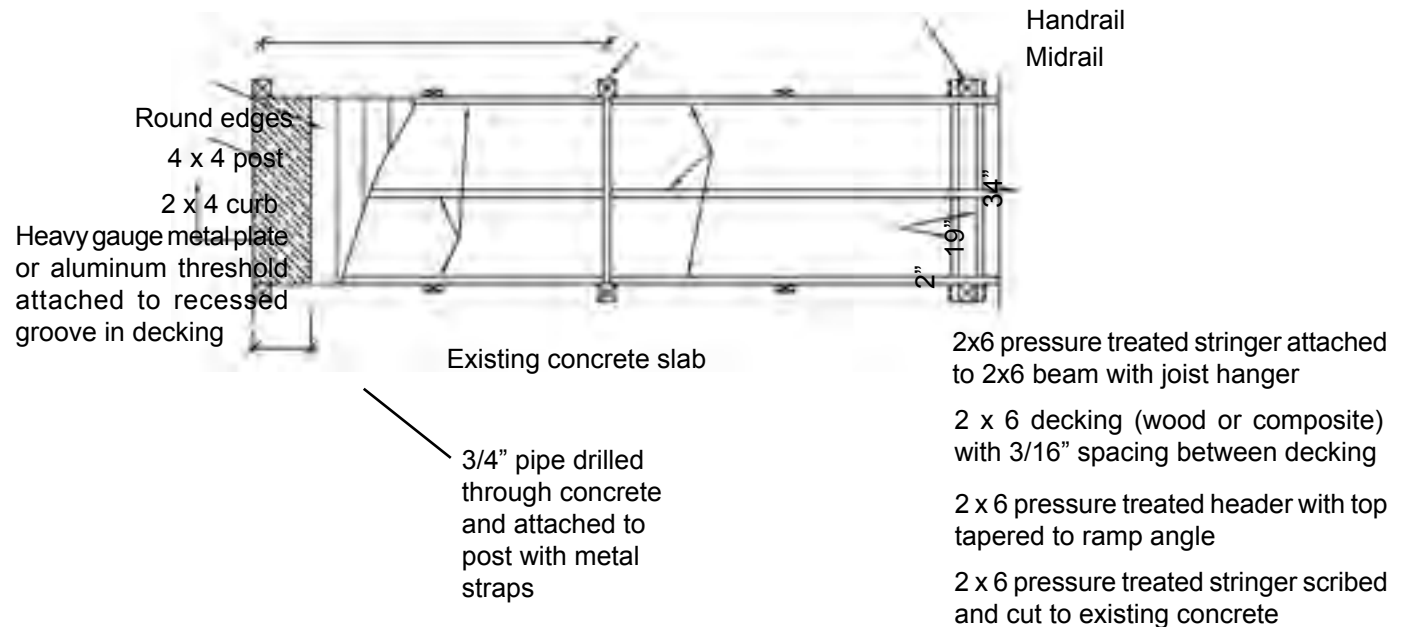
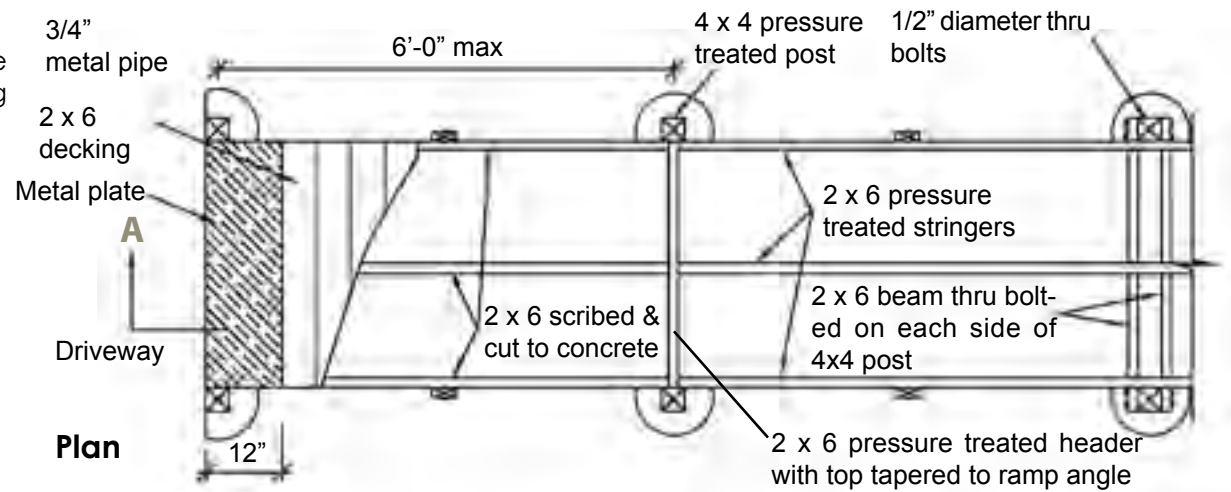

# Ramp Landings

Ramp landings are used to provide flat, safe areas where a user can open a door or switch directions while using the ramp. There are three typical ramp landing types: a top landing, a 90 degree landing, and a switchback landing.

## 90° Landing Plan

This mid landing is used when a ramp switches direction 90 degrees. For a 90 degree turn, a user needs a wide turning radius. It is recommended that the platform is 5'x5' and that the ramp runs on the outer most edges of the landing to ensure adequate turning space.

A 2x4 joist is used to span up to 5'-0" on the landing. If the span is greater than 5'-0", change the 2x4 joists and header to 2x6.

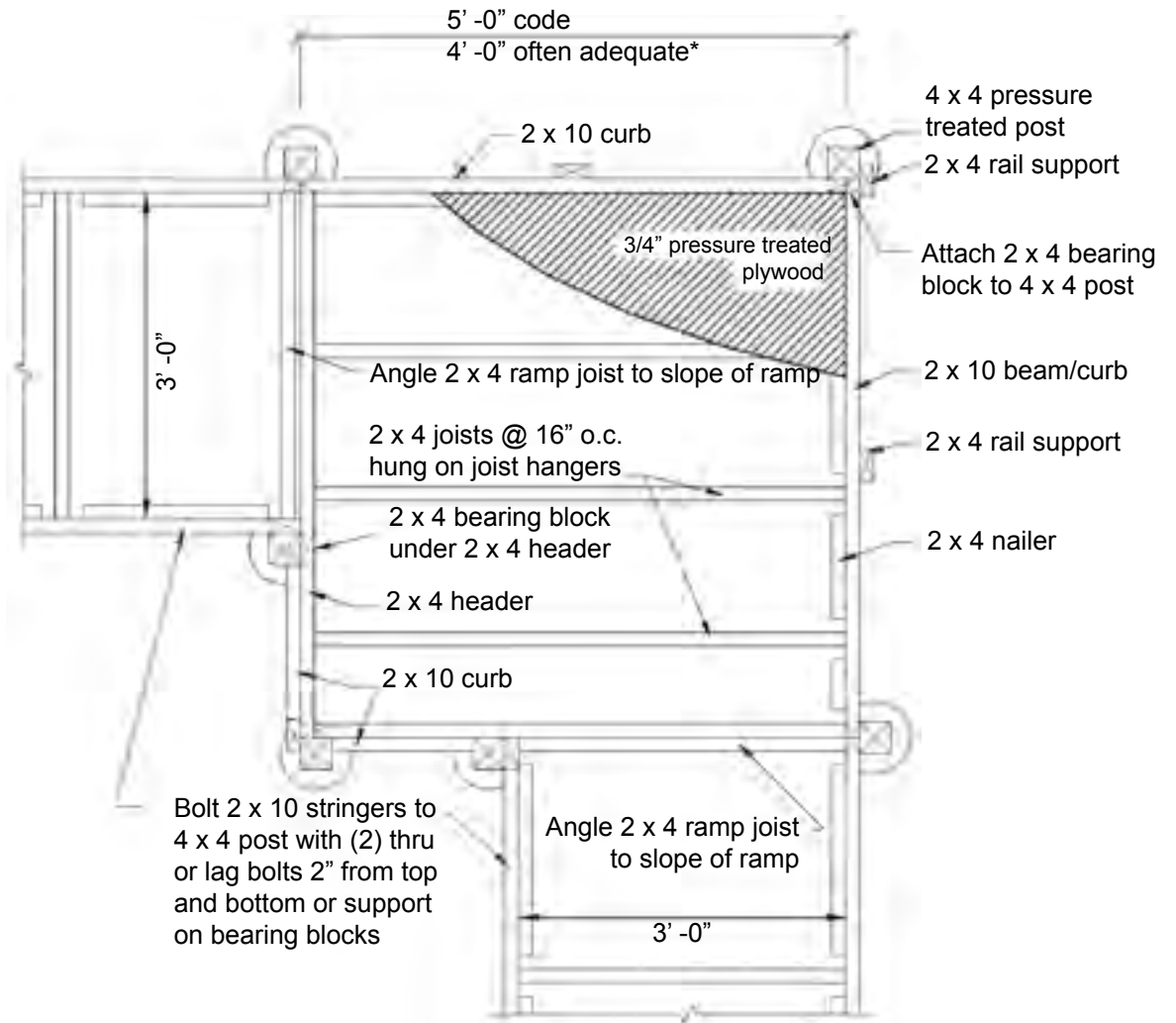

\*must be approved by building official

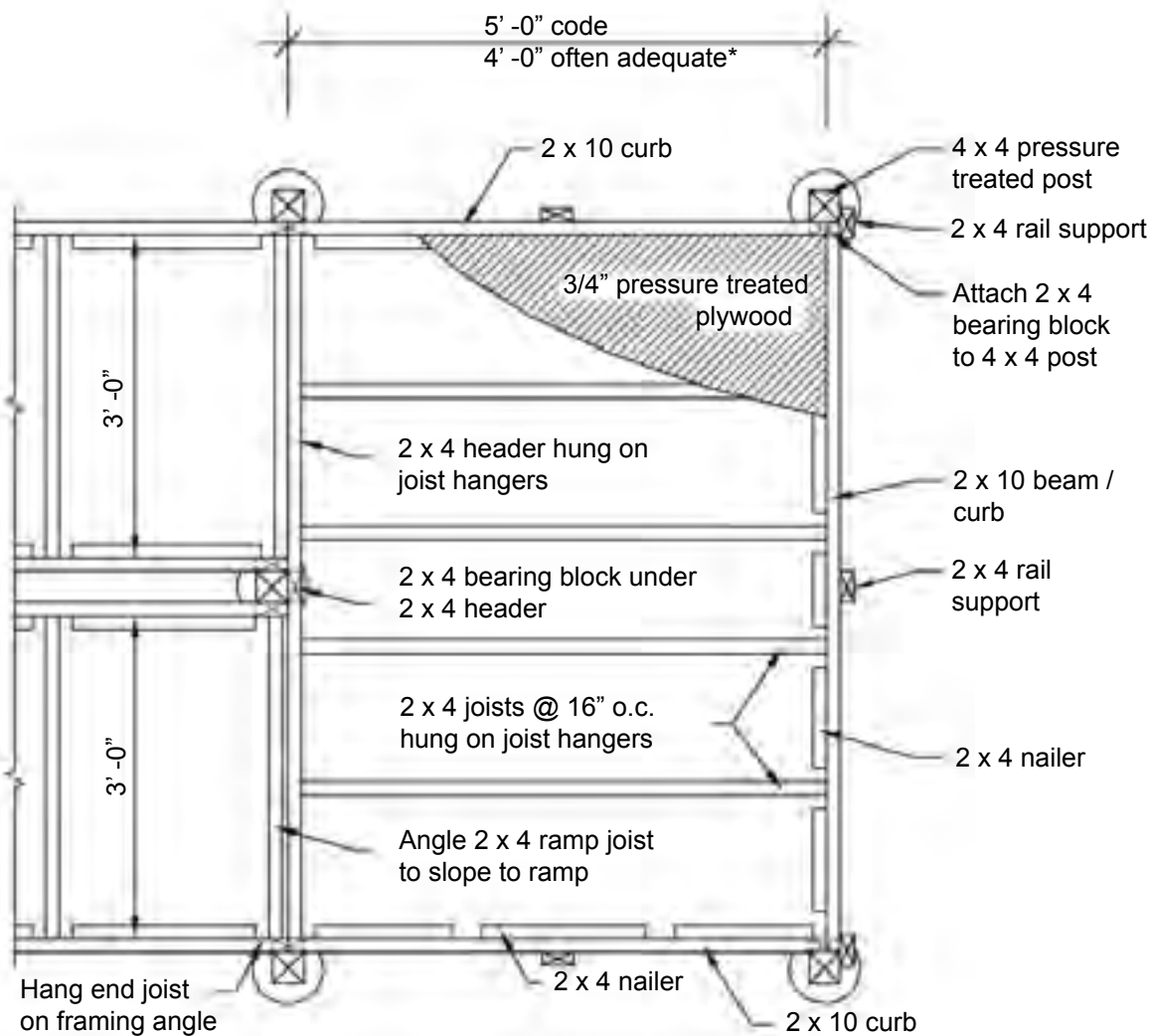

### Switchback Landing Plan

Switchback landings are used when a ramp changes direction 180 degrees. A 2x4 joist is used to span up to 5'-0" on the landing. If the span is greater than 5'-0", change the 2x4 joists and header to 2x6.

On switchback ramps the inside handrails on the bottom ramp run can be mounted on metal handrail brackets. The brackets are attached to the 4 x 4 posts and 2 x 4 rail supports.

\*must be approved by building official



### Top Landing Plan

Top landings are used when a porch has an additional step into the home. A top landing raises the porch to the threshold level and provides a level transition.

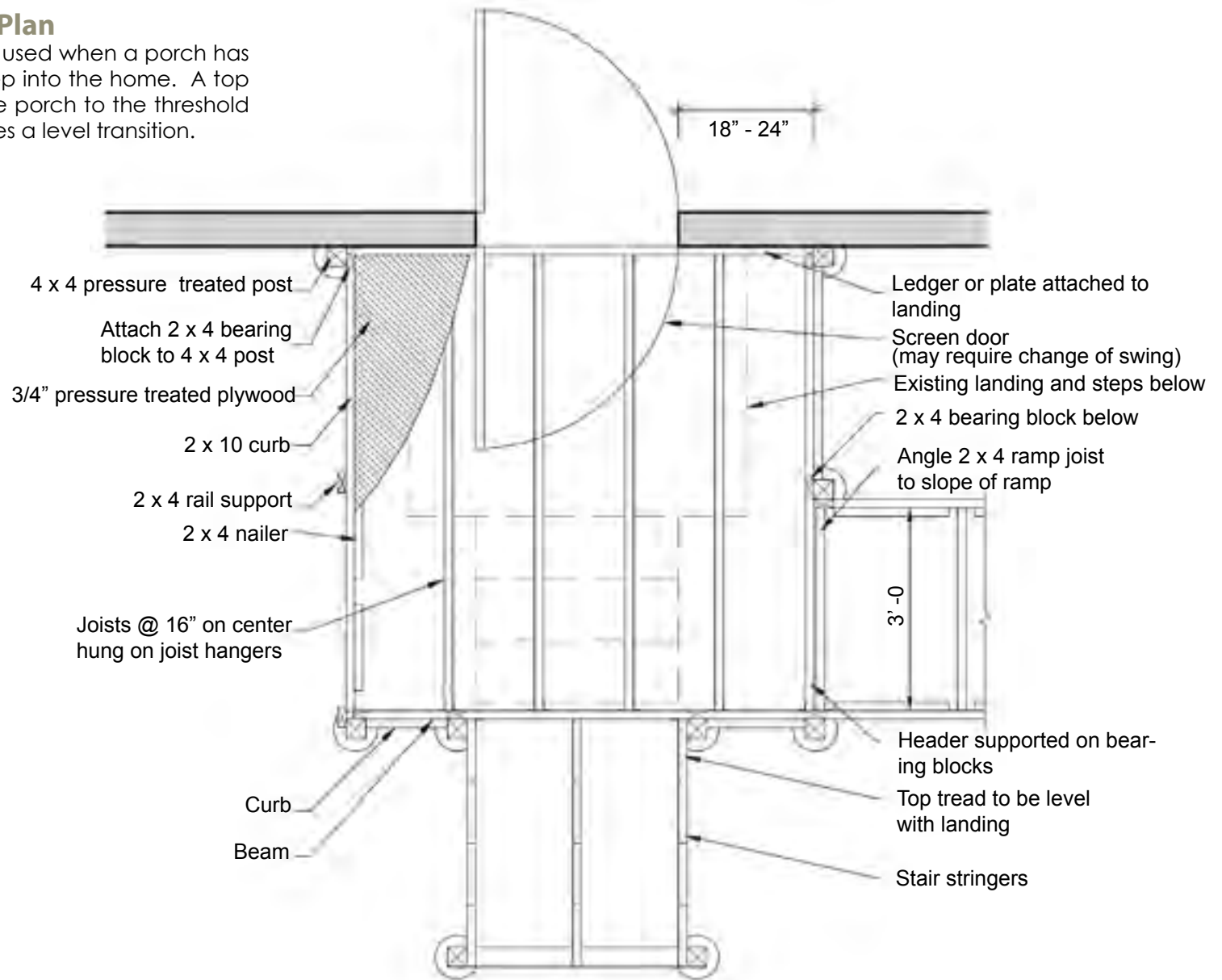



## Landings

These photographs show various landing configurations and how they can be designed to meet a variety of needs and conditions.

A ramp can sometimes be integrated as part of a deck and provides easy entry into the home for everyone. The example shows the ramp along the side of the home

A typical example of a front entry ramp shows the landing built over existing steps. This creates a level platform at the front door.

The carport ramp illustrates that ramps and landings can be designed to meet a person's specific needs. This ramp was built without railings at one side to allow for access from a van.

The last picture is a landing with a gate. It was designed for use both as a deck and a horse-mounting platform for a person who uses a therapy horse.



# Porches

A step at the doorsill usually makes it necessary to either build up the existing porch, add a separate ramp and platform, or install a wedge ramp.

A built up porch is usually formed as a box with joists hung from each side and anchored to the existing porch with metal anchors and vented to allow for air flow. It is important to note that adding a platform to a porch adds an extra step to the existing stairs due to the new height. This new step often requires that the entire porch stairway be rebuilt so that the new step is similar in height to existing steps to meet building codes.

On large porches, sometimes a wedge ramp can be placed to make the doorsill transition. The wedge is often steeper than a typical ramp and the user's individual ability needs to be checked before building. Often it works well for an electric wheelchair or scooter that can negotiate a 1:9 slope.

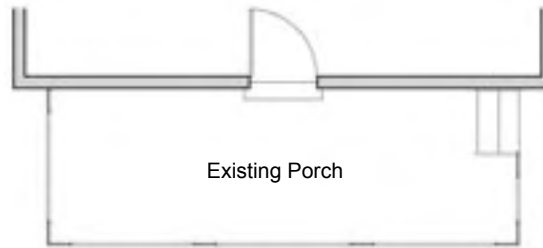

**Existing Porch**

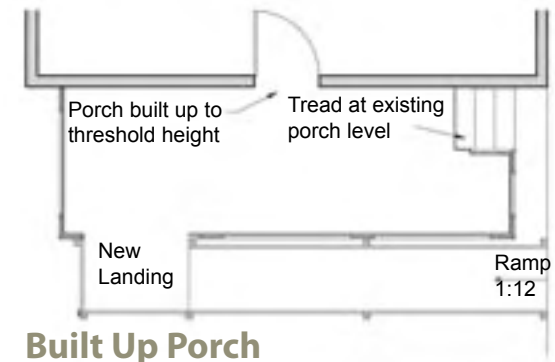

**Built Up Porch**

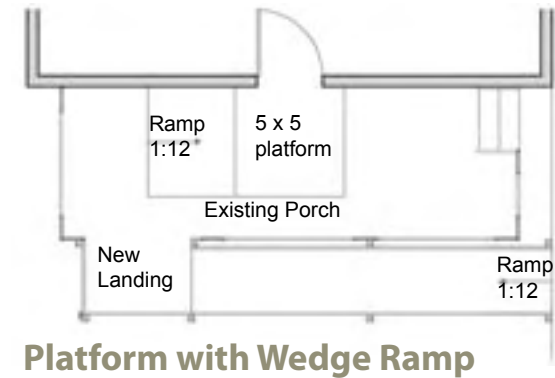

**Platform with Wedge Ramp**

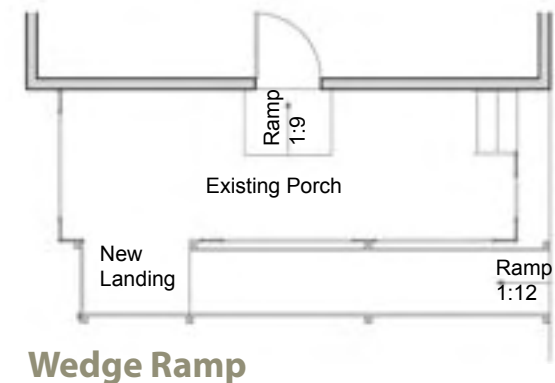

**Wedge Ramp**

## Wedge Ramps

In some situations a wedge ramp is all that is needed to make a home accessible. A wedge ramp should meet the minimum 1:12 slope guidelines. For rises less than 3", a 1:8 slope is allowed by code. Sides of wedge ramps should have tapered edges to prevent tripping. When building any of the following ramps use construction adhesive to attach wood to concrete. Exterior grabber screws are used to attach plywood to joists and supports. The top of ledgers are cut to match the ramp angle.

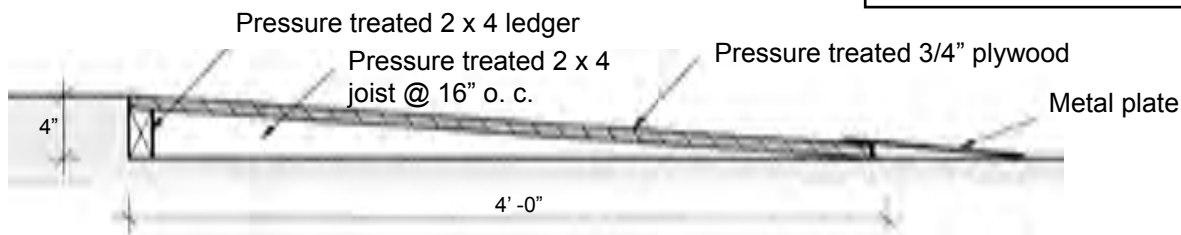
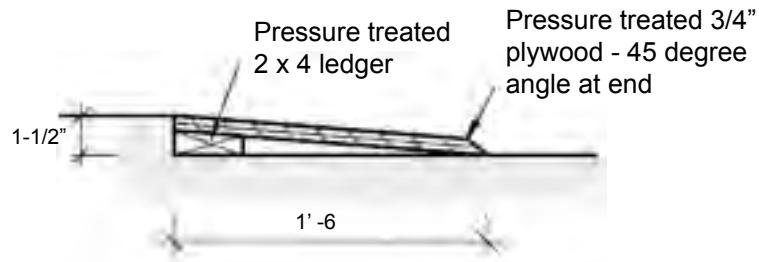
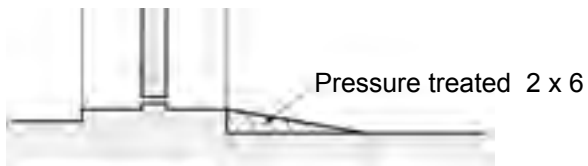

## Thresholds

For wheelchair use the maximum vertical rise allowed is 1/4". Most accessibility standards require that thresholds at the doorway be 1/2" maximum height for regular doors and 3/4" height for sliding doors. Raised thresholds should be beveled with a slope not greater than 1 vertical to 2 horizontal. Ramped sills are available from hardware suppliers in metal or rubber and come in a variety of sizes and types. Note the sloped edge on the threshold shown.

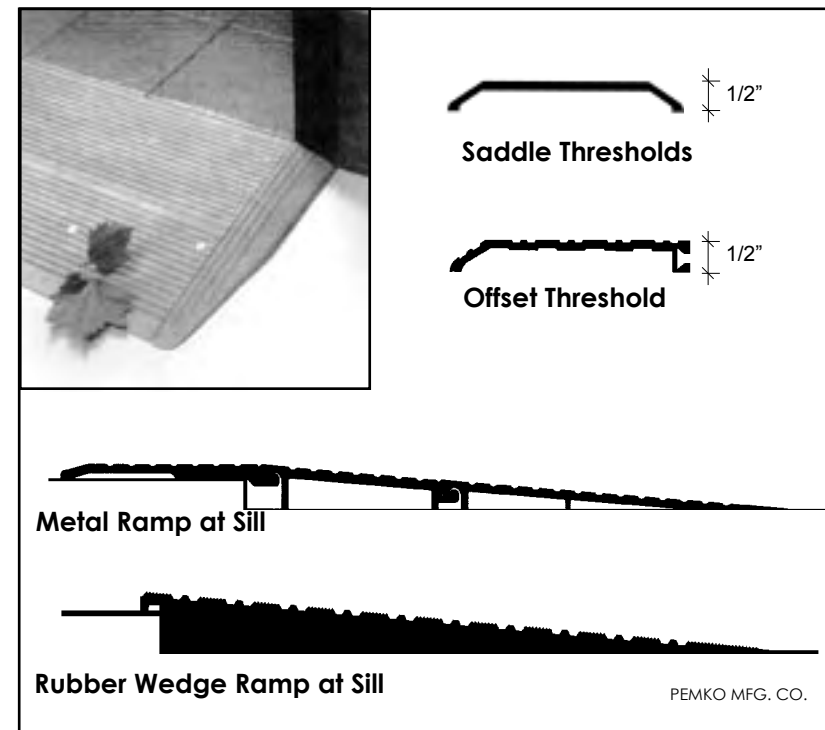

# Stairs

## New Steps for New Landing

A new set of stairs is often required when building up a landing to accommodate a ramp or lift.

As shown in the illustrations, the landing is built up to threshold level and new steps are built over the existing steps. If the top stair tread is level with the porch, it provides more safety for a person in a wheelchair by allowing additional horizontal space between the path of travel and the top stair riser.

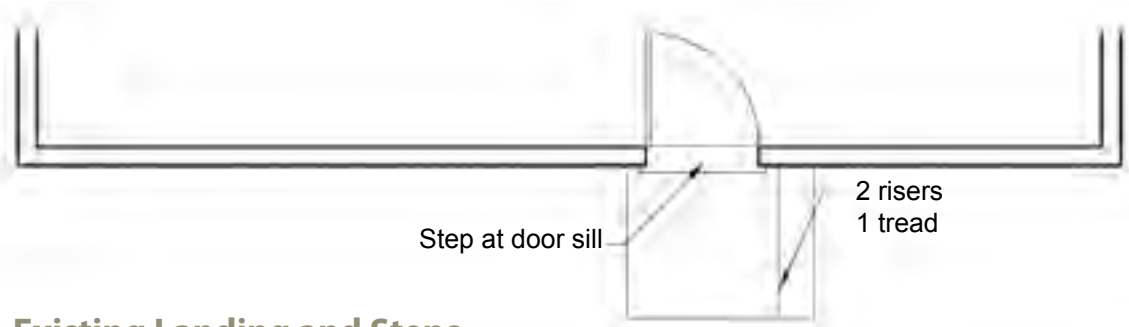

## Existing Landing and Steps



## Platform with Additional Step

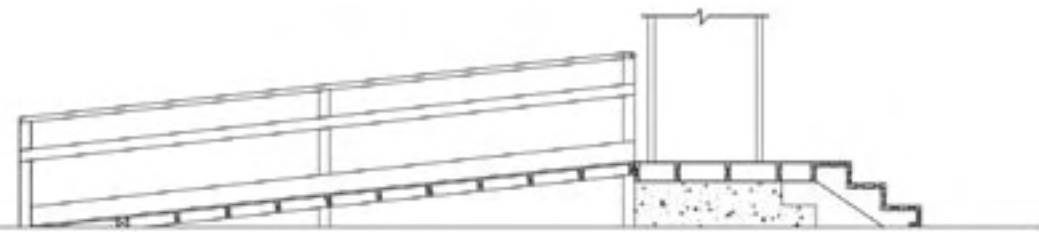

## Section



### **New Steps**

These examples show the additional tread at the top landing level. The left photo shows a concrete landing and steps that were modified to accommodate a porch lift by raising the landing and adding steps with an overpour of concrete. The photo on the right shows a top tread at the landing level which moves the top riser away from the path of travel.



### **Railings**

Railings are an important addition because of the stability and safety that they provide for the user. The photo on the left demonstrates a simple rail addition to an exterior porch. The photo on the right is a railing for an interior step.

# Alternative Wood Framing

## 2x4 Ramp Construction

This alternative allows for construction of a ramp using only 2 x 4 lumber. This option is applicable when the ramp is built on concrete driveways or walkways.

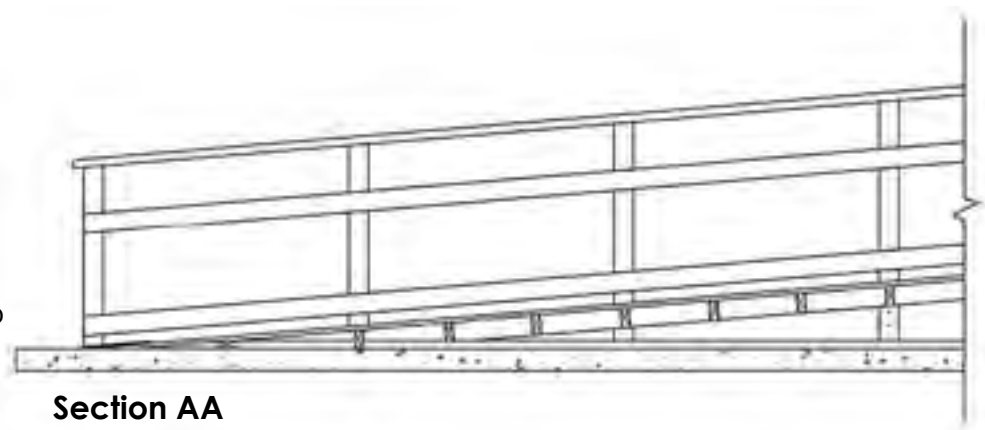
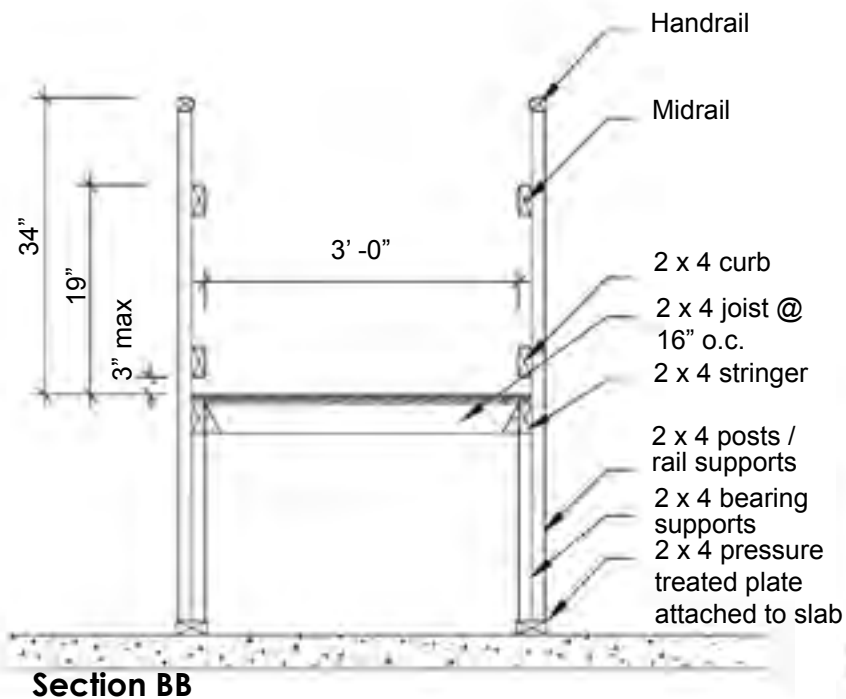
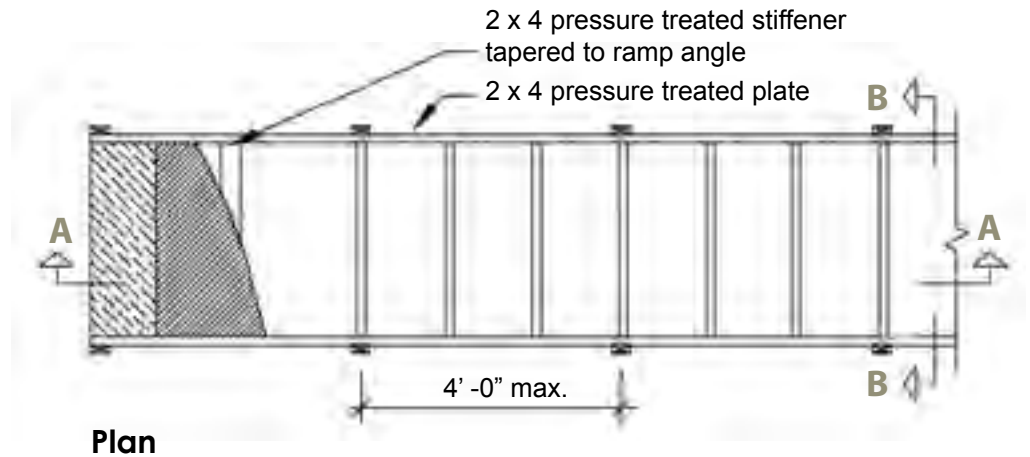



PORTA-RAMP



PRAIRIE VIEW INDUSTRIES

## Portable Ramps

These ramps are easily moved and come in various lengths. The multi-fold ramp can be folded over for weather protection when not in use. When sizing a portable ramp, the slope should not exceed the standard 1:12. The wheelchair tracks shown should only be used for short term temporary situations and with a strong person to help.



## Modular Ramps

Preliminary planning considerations for a metal ramp are similar to those for wood or concrete ramps. However, since the ramp is modular, the available sizes of ramp sections need to be adapted to the existing slope and site so that a maximum slope of 1:12 is achieved.

Other considerations include determining if a concrete walkway is necessary to connect the ramp to a driveway or sidewalk. A platform may also be needed over the existing porch to make the entrance level with the height of the existing threshold and new steps built. If grade is uneven or the soil unstable, the posts may need to be set on concrete pavers or blocks.



# CONCRETE RAMPS

---

Concrete ramps are another option for home entry. Concrete is more durable and permanent than wood ramp construction but may be more difficult to build. The ramp layouts are the same for concrete as for a wood ramp: straight, 90 degrees, switchback, or a variation. Handrails are built in a variety of styles and materials.

The finished surface of the ramp should have a brushed finish perpendicular to the path of travel.

The picture at the upper left shows a combination wood ramp with a concrete pathway. The slope of the pathway is a 1:20 slope so handrails are not needed. The upper portion is a ramp at 1:12 slope and handrails are required.



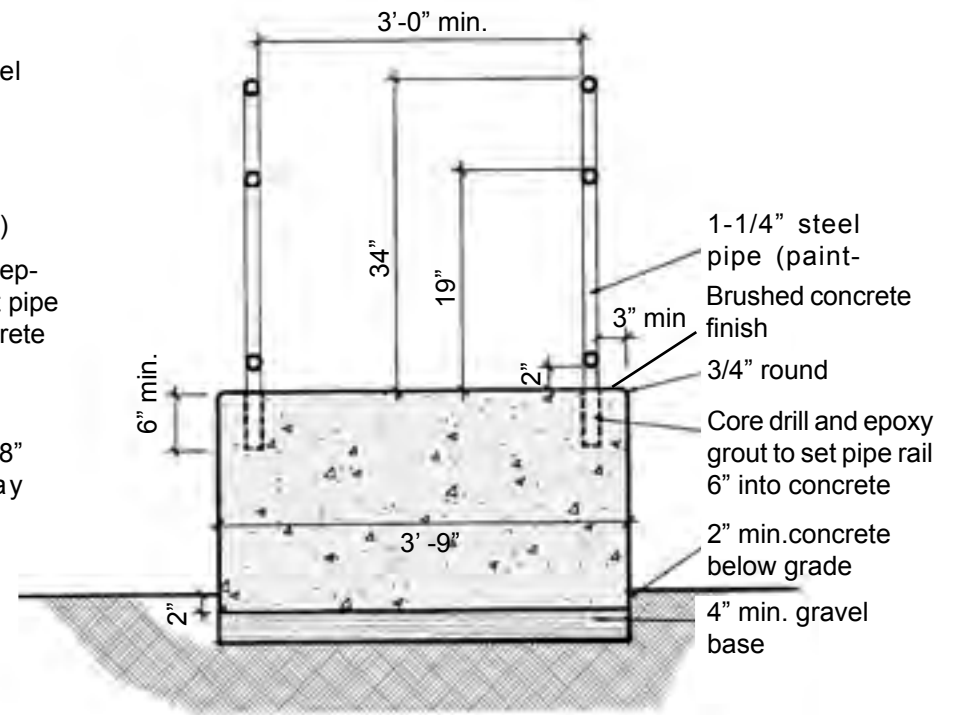
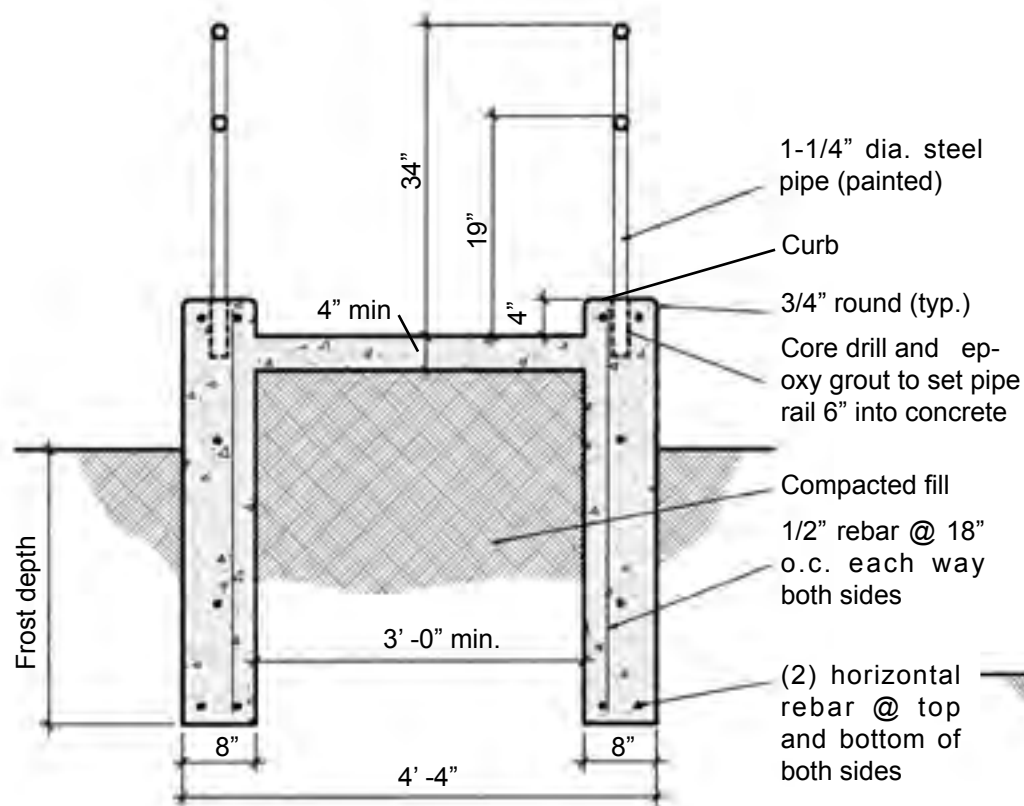

### Concrete Ramp with Concrete Footing

This option is usually used for longer ramps or for soils that require deeper footings for weather protection or bearing. Footings need to extend to the frost depth required for the area and should be confirmed with local building officials. Can be placed with monolithic or separate pours.

### Solid Concrete Ramp

This option can be used for shorter ramps. It is not appropriate for all soils and climates, so it is important to check with your local building officials for approval. The handrails have a rail near the lower edge of the ramp for edge protection. Another option is to have a concrete curb as shown in the adjacent drawing.

## LOW RISE STEPS

---

Low rise steps are an alternative for a person who does not need a ramp but cannot manage regular steps. Smaller 4" high steps allow a person to still use the stairs while providing an easier climb. In addition, the tread depth can be increased to accommodate a walker. When planning the steps, verify the width of the walker to be used as walkers come in a variety of sizes. With a walker, low rise steps are often easier to manage than a ramp because the ramp angle can create an awkward and unsteady position for a person leaning on a walker.



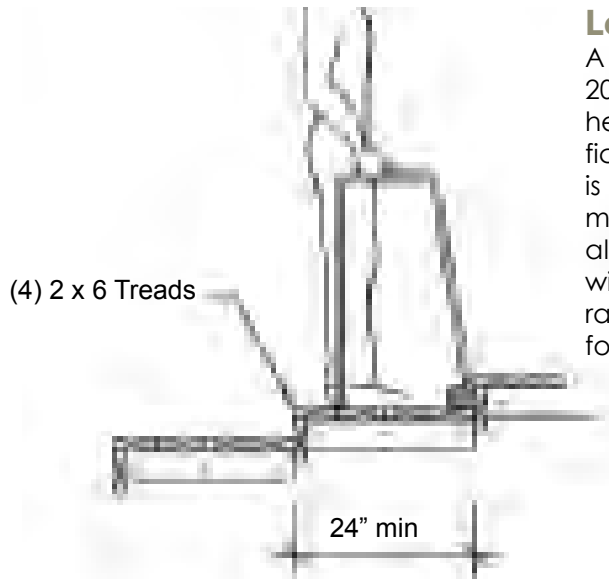

(4) 2 x 6 Treads

24" min

### Low Rise Steps

A riser height of 4" (minimum allowed by 2003 International Building Code) is often helpful for a person with leg or knee difficulties. A 12 inch minimum tread depth is also required, but a deeper tread can make climbing easier. The tread should allow the foot to rest completely on it without projecting over the edge. Hand-rail requirements for stairs are the same as for ramps.

Open risers are a tripping hazard and should be avoided. In this detail we have used tread supports on the stringer rather than notching a stringer for support. The riser is attached to both the tread above and to the back of the tread below. If the treads are not supported by the riser, maximum span is 2' -0" for the 2 x 6 treads.

### Low Rise Steps with Walker

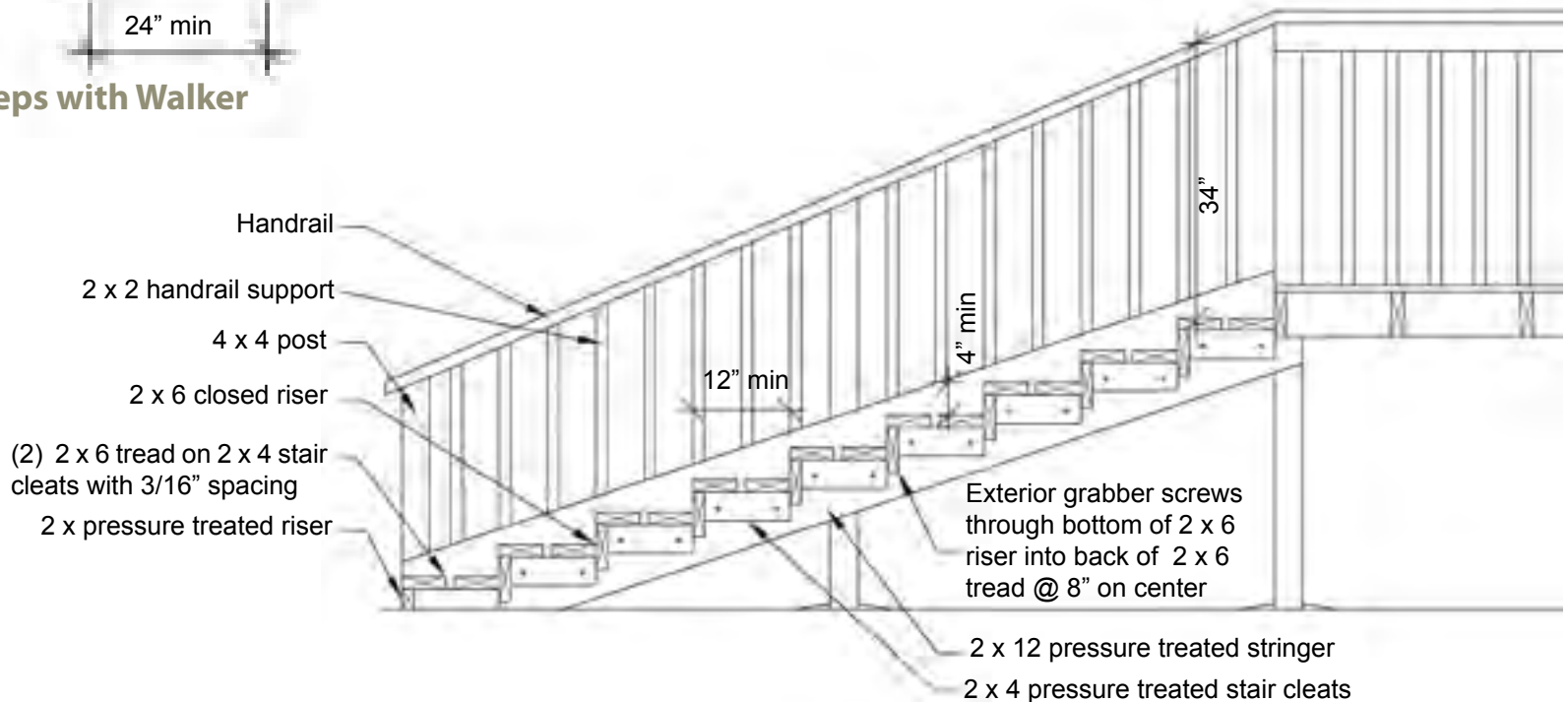

Handrail

2 x 2 handrail support

4 x 4 post

2 x 6 closed riser

(2) 2 x 6 tread on 2 x 4 stair cleats with 3/16" spacing

2 x pressure treated riser

12" min

4" min

34"

Exterior grabber screws through bottom of 2 x 6 riser into back of 2 x 6 tread @ 8" on center

2 x 12 pressure treated stringer

2 x 4 pressure treated stair cleats

### Stair Detail

# HARDWARE, LUMBER, & FINISHES

## Structural Lumber

The ramps in this guidebook were designed using Douglas-fir, no. 2 or better for all structural lumber. Pressure treated lumber is used for all members within 6 inches of earth or in contact with concrete.

## Decking

Options for the ramp and platform decking include:

### Pressure Treated Plywood

This is recommended whenever the ramp or landings are outside and uncovered. Always use where plywood is in contact with concrete or within 6 inches of the ground.

### Marine Plywood

More expensive than regular plywood but more resistant to water damage. It may be the material of choice in climates with high humidity.

### Oriented Strand Board (OSB) or Exterior Plywood

These can be used when the ramp is in a garage or covered porch. Plywood, over time, can delaminate and OSB can deteriorate with standing water.

### 2 x 6 Lumber

Available species include; Redwood which is very decay resistant but is a limited resource; Western Red Cedar that has decay resistant heartwood; and Douglas Fir that is not decay resistant and should be thoroughly waterproofed, stained or painted.

### 2 x 6 Composite Decking

This is a man-made composite material. This material is generally more expensive than other materials but is very durable and does not need staining or painting. It is recommended that the non-skid finish, similar to a brushed concrete finish, be used to prevent it from becoming slick when wet.

## Fasteners

### Carriage Bolt / Lag Screw

Use lag screws or carriage bolts for rigid connections where strength is important—beam to post, stringer to post, etc.



Carriage Bolt

### Expansion Bolt

Use for attaching to a masonry wall or to a concrete slab.



Lag Screw



Expansion Bolt

### Grabber Screw

Use hot dipped zinc, galvanized, aluminum, or stainless steel for exterior applications.



Grabber Screw

Illustrations only  
Sunset Publishing Co.

## Framing Connectors

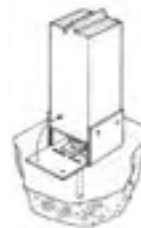

Post Base Anchor  
(for use on an existing slab)



Post Base Anchor  
(for use with poured footing)



Stringer Tie

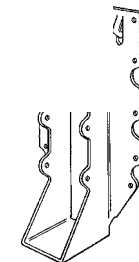

Joist Hanger

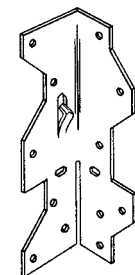

Framing Angle

Illustrations only  
Simpson Strong Tie Co.

---

## Materials for Ramp Surfacing

### Sand Paint

This is porch or deck paint used with silica sand. It is inexpensive and easy to apply. However, it is only durable as long as the life of the paint. It does not provide a great deal of traction when exposed to ice and snow conditions unless maintained.

### Waterproof Deck Surfacing

Several manufacturers make a nonskid deck surface material that is applied as a liquid in several coats. It is fairly durable and traction is similar to sand paint. If it is applied on a plywood deck, the decking should be exterior plywood.

### Carpet

There are many different carpets available. Ramps can be designed using a 20 oz. nonskid, indoor/outdoor, olefin level loop carpet with ultraviolet sun screen. Install with a minimum of seams. Use metal carpet strip at all surface finish transitions. Carpet should be fully glued with a waterproof glue.

This type of carpet works in dry climates to lend traction to the surface although it will need to be replaced in time. This carpet might cause problems with mildew and moisture in a humid climate. (Turf type carpet is to be avoided. It gets very slick in wet, snowy, or icy weather.)

### Rolled Roofing (Pebble-grained)

This makes a good nonskid surface for wood ramps. However, the small pebbles come loose over time reducing traction.

### Ribbed Rubber Matting

Install the ribs to run across the width of the ramp to provide better traction. This surface will deteriorate over time and may need to be replaced.

## Finishes

### Paint

Over time, the paint may peel and flake. It will need to be sanded and painted periodically.

### Stain

An oil base UV stain (2 coats) is recommended for use on most ramps.

The choice is between a semi-transparent stain and a heavier bodied opaque stain. The opaque stain obscures the texture of the wood whereas a light bodied penetrating stain leaves the wood texture. In the semi-transparent finishes the darker colors cover better. For lighter colors the opaque, heavy stain is usually preferable. The treated lumber is the most difficult of all the wood material to cover.

Over time the stain will wear thin and need to be reapplied.

### Brushed Concrete

All new concrete surfaces should have a brushed finish perpendicular to the direction of travel to provide traction for users and flat landings should be sloped to drain away from buildings at 1:48 slope (1/4" per foot or a 2% slope).

# PORCH LIFTS

---

When the total rise at the entry approaches 40 inches, it is frequently just as cost effective to provide a porch lift instead of a ramp.

The most common situation requiring a lift is a split level home. It can often be accommodated from a back deck or in a garage.

## Location

Lift placement is determined by several factors: path of travel, weather protection, and user preference. Lifts can be located off of decks, porches, in garages, or in carports.

As with a ramp, weather exposure and drip lines need to be considered.

## Site Preparation

The site usually needs some accommodation to allow for lift installation. These may include:

### Electrical

A lift requires a 20 amp separate electrical circuit.

### Concrete Pad

A concrete pad is needed to support the lift. The pad needs to be 4" thick and 3500 psi concrete to meet most manufacturer's specifications. These specifications should be verified with the individual manufacturer. The pad under the lift should be level.

### Path

A concrete path to the lift location is frequently required when the lift is located off a deck or porch.

### Railings

Railings often need to be modified to allow for the top gate of the lift.

### Wall

There needs to be a flush wall between the deck and the lift so that a person's hand or foot will not get caught when the lift is in operation.

### Platform

Some porches require adding a platform on the porch to raise the existing porch up to the door sill level.

## Purchasing

Lifts can be purchased from various manufacturers. Dealers are listed in the yellow pages or can be found by calling the medical supply distributors in the area.

## Maintenance

Like any mechanical device, lifts do require regular maintenance. Most manufacturers recommend a six month regular check up by a lift/elevator technician to check safety systems, fluids, and lubrication.



ACCESS INDUSTRIES INC.

## Lift Options

The mechanical system of a lift is usually hydraulic or screw drive. Some units operate from a battery which is recharged automatically. Other units operate directly from the electric power.

Lifts come with standard features and also the choice of extra options. Some of these options are listed here.

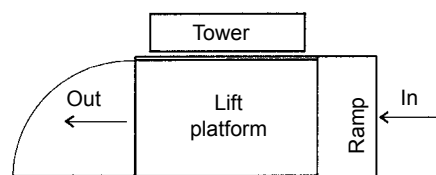

**Straight Through**

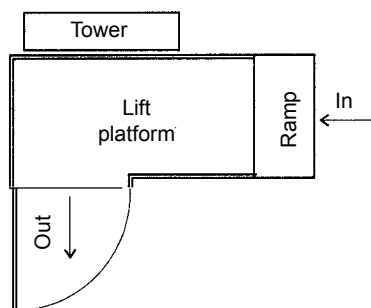

**90 Degree**

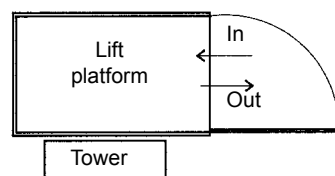

**Straight In and Straight Out  
(Same Side)**

## Platform Size

The size of the lift platform is determined by the size of the mobility aid of the user. A larger platform may also be needed if another person will be accompanying the person with the disability on the lift. Typical platforms are 36" wide and 48", 54", or 60" long.

## Entry/Exit Option

Lifts come in a variety of entry/exit options to accommodate a number of situations. These are:

### Straight Through

This is the standard entry/exit option and is usually the most economical if the situation can be adapted for it. It is also an easy situation to maneuver for the person with a disability.

### 90 Degree

This option is usually the choice in a tight situation where a straight through option will not work. To allow better maneuverability a 42" wide upper gate and a longer platform can be helpful.

### Straight In and Straight Out

This option is used most frequently in a shaft enclosure. In this situation the door of the shaft needs to be flush with the inside shaft wall to prevent a person from catching a hand or foot during operation.

## Gates

Lifts usually come with a standard option top gate and a bottom ramp that folds up to act as a safety gate when the lift is in operation. A gate can also be installed along with the bottom ramp platform if needed. It is an extra option from most lift manufacturers.

## Battery Back-Up

Some hydraulic units come with a standard battery backup. In emergencies there needs to be a way to operate the lift if electrical power goes out.

## Exterior Package

Some units come with the option of an exterior package for cold weather protection. This may include extra electrical coverings, heater elements, and airline hydraulic fluid for a hydraulic unit.



# INTERIOR ACCESS

## Doorways

Besides home entry, interior doors that are too narrow cause the most problems for people using wheelchairs or walkers. Ease of use and building codes require accessible doors to have more than 32" of clear opening. This is the measurement from the door face to the latch side door stop when the door is opened 90 degrees.

Most wheelchairs, manual and electric, are about 27" wide. In retrofitting doors to accommodate a wheelchair, installation of swing-clear hinges should be considered first. Swing-clear hinges add 2" to the clear opening of the doorway. An existing 2'-6" wide door can provide 30" of clear passage space and someone using a wheelchair can get through if they ride "knuckles in".

This is not possible with 2'-4" doors that some builders are still using on bathrooms in single family homes.

The door thickness and the door stop reduce the door opening by approximately 2-1/2". Doors 3'-0" wide are recommended. This provides a clear opening of 33-1/2". In some cases a 3'-6" wide door is advised for easier turning from a narrow hallway.

### Standard Swing Door

The door swing and the space on each side affect accessibility. The pull side of the door needs more room than the push side for manipulation of the handle. Sometimes the swing of the door needs to be reversed for easier use.

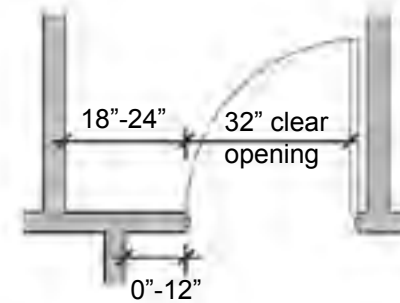

### Pocket Door

This door is often considered to be easy to operate because it does not require space for the door swing. However, when turnaround space is limited it may be difficult for a person in a wheelchair to reach behind and close the door. The typical lift handle can also be difficult to manage. "D" type handles mounted and recessed on the side of the door can make it easier to open and close. Heavy duty tracks and hardware that slide easily also improve ease of use.

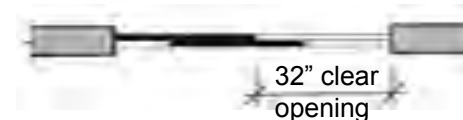
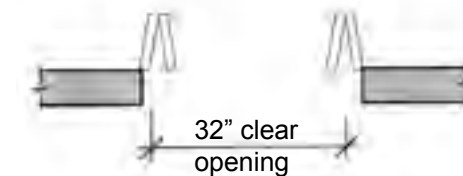
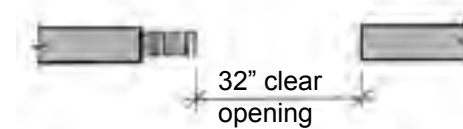
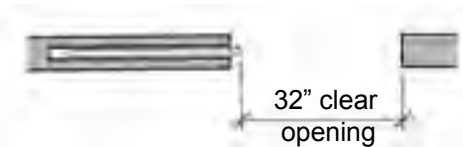

### Accordion Door/Bifold Door

Folding doors require less force than a pocket door to operate, but will take up part of the clear width of the door opening. This needs to be considered when planning for door width.

### Sliding Glass Doors

Sliding glass doors are usually heavy and can be difficult to slide. The tracks are often difficult to cross and usually have a higher threshold than standard swing doors. Wedge ramps can help the threshold transition. Handles should be mounted on both sides and the doors should be adjusted to slide easily.

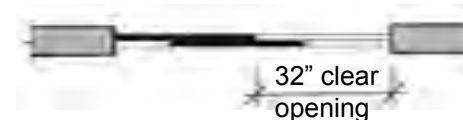

## Door Modifications



### Swing Clear Hinges

These hinges can be installed on an existing door allowing the door to swing clear of the opening. In the fully open position, this adds an extra 1-1/2 inch or 1-3/4 inches to the clear opening depending on the door thickness. Cutting the door stops and installing swing clear hinges can add several inches to the clear opening.

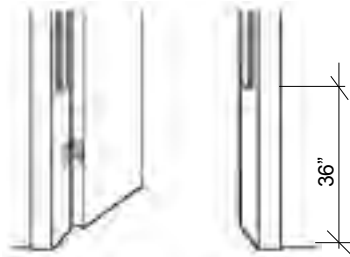

### Door Stops

Door stops can be cut from 36 inches above the floor on both sides of the door opening. This usually will allow an added 3/8 to 1/2 inch on each side of the clear opening. The remaining stop will be enough for closing the door.

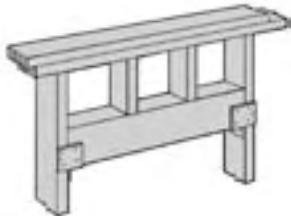

### Widening the Existing Door

If the space on each side of the door allows, the door can be widened by reframing the entire door. Another option is to remove one of the 2 x 4's on each side of the door opening and hang the header with metal brackets. This will add approximately 3 inches to the existing opening.



SCHLAGE



NT FALCON LOCK  
2" Handicapped Lever  
(optional)



AMAZING CONTROLS, INC.

### Hardware

All pulls, locks, and handles on doors need to have a shape that is easy to operate without grasping or twisting. Lever or U-shaped handles, push bars, and keyless entry controls are good options. Automatic door openers are also available.

# Lift Types

## Stairway Lifts

For multistory homes, stair glides can offer a safe and comfortable means to access different levels of the home for a person who is able to transfer. Some of the safety features include a rotating seat, a flush platform at the top landing, and battery backup.



ACCESS INDUSTRIES INC.



MEDITEK

## Inclined Platform Lifts

An inclined platform lift enables the user to move between floors without transferring from chair to lift. Features include a level platform at the top landing and a folding assembly for storage against the wall when not in use.

Often these lifts can be installed with minimal modifications to the home if stairways and landings have adequate width.



CONCORD



CONCORD

## Overhead Lifts

An overhead lift utilizes a motorized hoist to enable a person to transfer or be transferred easily. Features include a hoist, remote control, and various track configurations. The example shows a curved track with the door header and wall section removed. Units are also available that eliminate the need for door modifications.



APEX DYNAMICS





## Elevators

Another option is to install an elevator. It eliminates the need for lifts on existing stairs.

Space for an elevator can often be achieved by using existing closets or expanding into a bedroom.

In the case of new construction, an elevator can be planned for later installation by aligning the closets on each floor. The floor plan illustrated shows how it can be integrated into the overall design.



WHEEL-O-VATOR CO. INC.



SAVARIA INC.

# BATHROOM MODIFICATIONS

## Typical 5' x 8' Bathroom

This drawing shows a typical bathroom plan found in many homes. To improve accessibility the following alternatives should be considered:

- tub seat / transfer bench in existing tub
- install curb shower
- install roll-in shower

In addition to the above, grab bars, high rise toilets, and hand-held showers can provide greater safety and usability. Doors often need to be modified to allow someone using a wheelchair to enter and close the door.

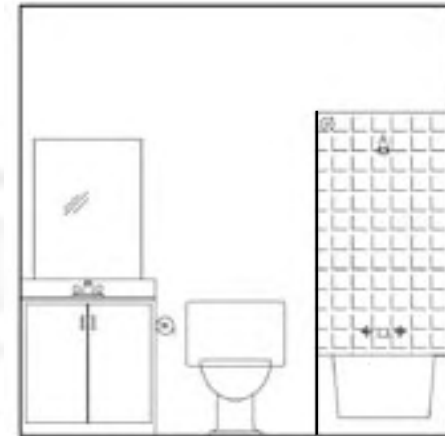
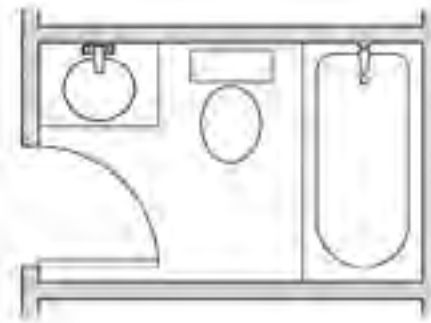

Typical 5 x 8 Bath

### Tub Seat / Transfer Bench

The first option is a tub seat or transfer bench which uses the existing tub. The tub seat allows a person to sit, providing greater stability. A transfer bench outside the tub allows a person to sit on the bench outside the tub, slide over, and maneuver their legs into the tub. Grab bars provide safety and a hand-held shower gives the user better water control. Using two shower curtains, one on each side of the transfer bench, provides easy access and improved water protection when clipped together.

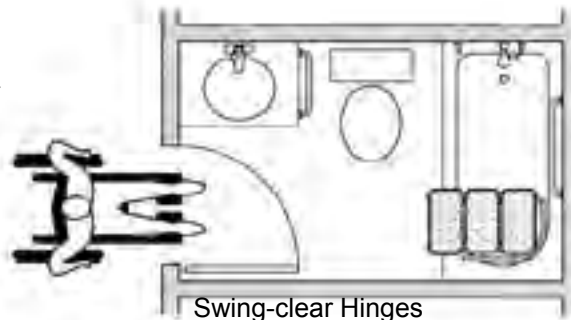

Transfer Bench Option



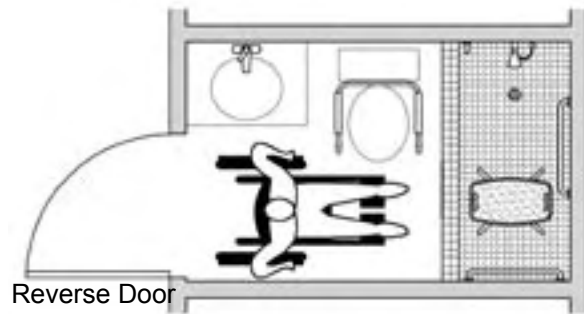

**Curb Shower Option**

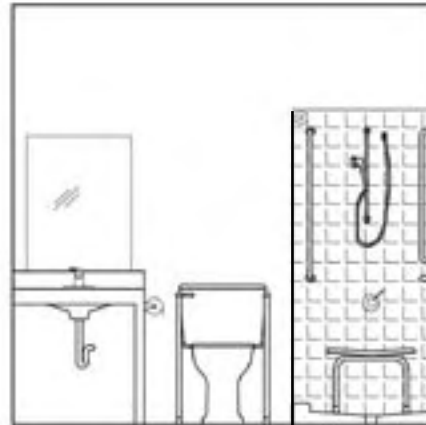

### Curb Shower

The second option is to remove the tub and install a shower with a 4" curb. If the person can manage a curb, this is often a more practical solution than installing a full roll-in shower. The shower floor and curb should use 2 x 2 non-skid swimming pool tile that is sloped to drain.

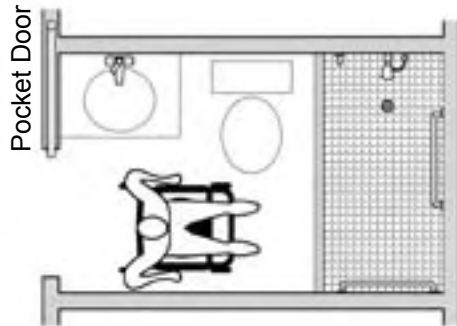
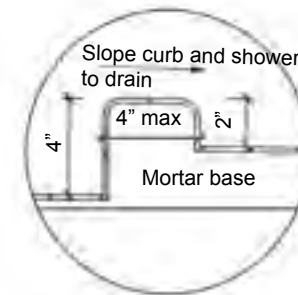

**Roll-in Shower Option**

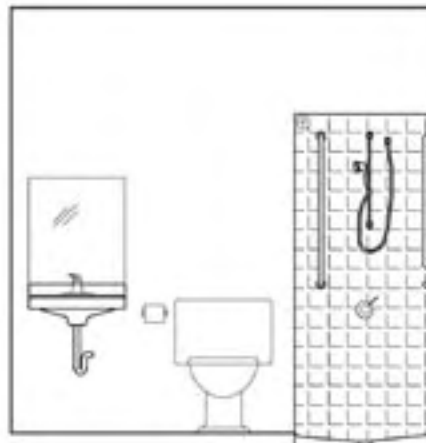

May require cutting and reinforcing floor joists

### Roll-In Shower

Another option is a roll-in shower. This may involve more extensive modifications in order to place the drain at the proper level and provide sufficient slope. A sloped marble threshold provides an easily crossed shower lip to act as a dam for shower water.

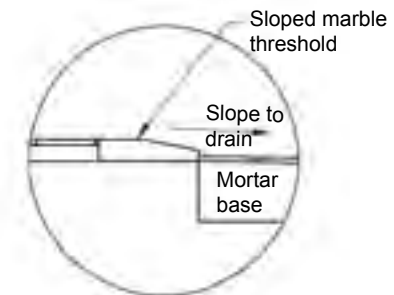

## Bathroom Alterations

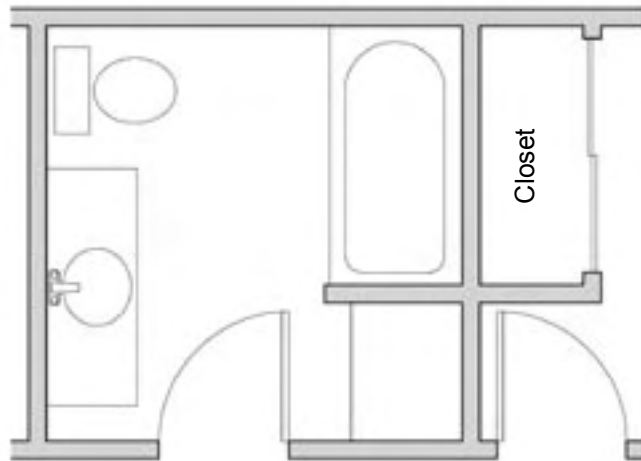

Another common bathroom layout is shown here with the tub opposite the sink and toilet. This layout offers additional options for modification as it is usually wider than the standard 5' x 8' bathroom.

### Curb Shower

By moving the sink, the bathroom is expanded to provide access to all the fixtures and sufficient turnaround space. By removing the tub and utilizing an adjoining closet a curb shower can be installed.

### Roll-in Shower

The roll-in shower uses the existing bathroom space and the shower is entered from a hallway. The advantage of this option is that the area is now long enough to provide enough slope to ramp up into the shower. This may eliminate the need for more extensive modifications, but hallway access needs to also be considered.

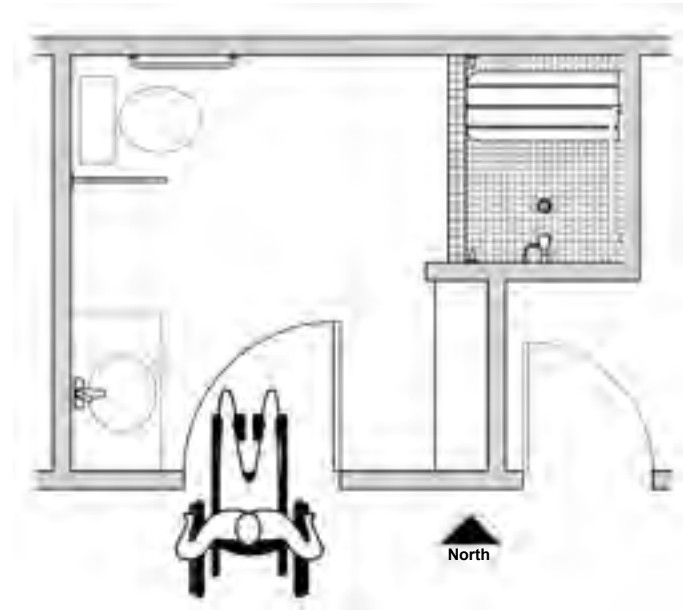

Curb Shower

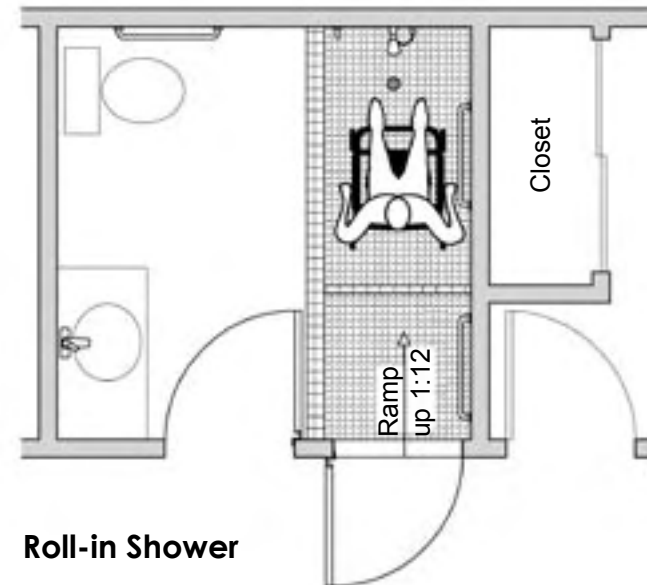

Roll-in Shower

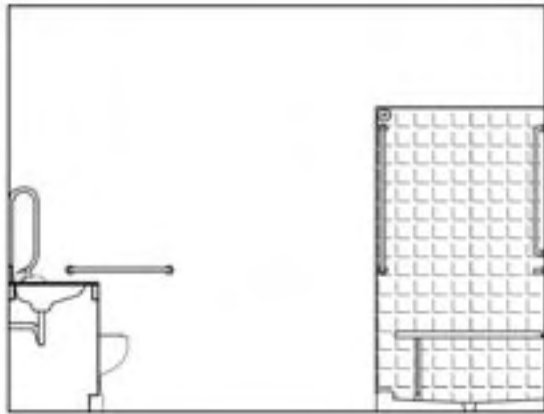

**North Elevation**

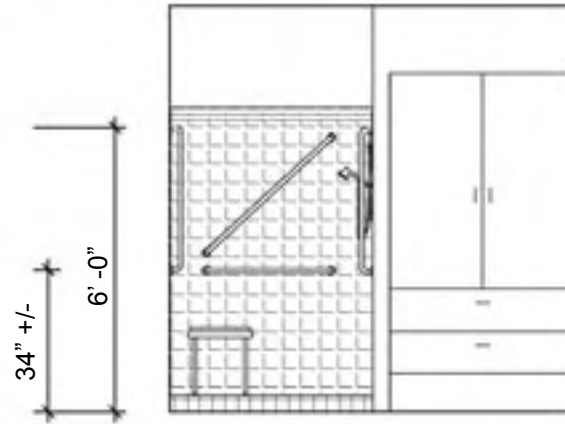

**East Elevation**

These drawings show in detail the curb shower bathroom from the opposite page.

**North Elevation**

This view shows the horizontal grab bars at the toilet, the vertical grab bars, and bench in the shower.

**East Elevation**

This is the side view of the shower showing the grab bar type and placement. The diagonal bar can aid a person in getting on and off the shower chair.

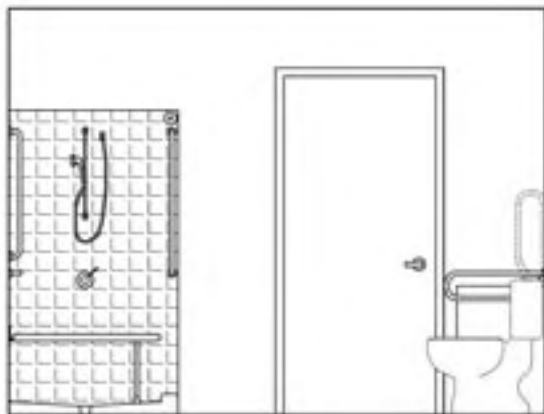

**South Elevation**

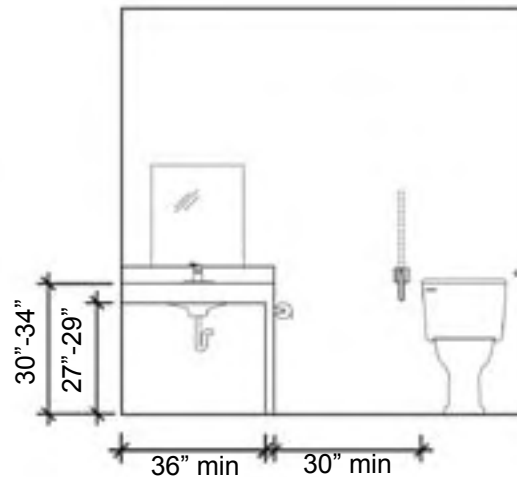

**West Elevation**

**South Elevation**

The hand-held shower provides easy movement of the shower nozzle. Also shown is the retractable grab bar at the toilet.

**West Elevation**

The height and placement of the roll-under sink is shown in this view. Insulation is installed on the supply and drain to protect the user from risk of burn.



---

### Tub Modifications

The left photo demonstrates the addition of a bathtub to a bedroom used with an overhead track system. A low shower rod for a curtain provides water protection when assisting with bathing. The right photo shows modifications with the least impact; a transfer bench with a side handle in an existing tub.



### Curb Shower

If a person with a disability can transfer onto a shower chair, a curb shower can be an easier and less expensive solution than a roll-in shower. Often, the shower can be installed in an existing tub space. It is beneficial to install the controls on the long wall so a person can reach them while sitting.





### Roll-In Shower

With a roll-in shower, the person with a disability transfers to a shower chair and then rolls into or is assisted into the shower. A roll-in shower can sometimes be installed in the space allowed for a tub, although a wider space may be desirable.

If there is sufficient space, a ramp can be built up to the shower level. However, it is sometimes necessary to cut down floor joists to accommodate a roll-in shower and lower the drain. This will need to be done with the assistance of a structural engineer.

A sloped marble threshold provides a low dam at the shower entry that can be managed by many people using shower chairs.



### Cabinet Modifications

Many times a change of fixture is all that is needed for accessibility. A hand spray can be added to sink or toilet plumbing to provide a convenient cleaning option.

A roll-under sink can be made by modifying an existing cabinet, insulating the pipes, and installing a lever handle faucet. A panel could also be used under the sink to both hide the plumbing and provide protection from the pipes.

# KITCHEN MODIFICATIONS

Kitchen design needs to include food preparation activities, maneuvering space and user preference. Although a kitchen may not meet all accessibility guidelines for a fully accessible space, modifications that help make a kitchen more usable for the person with a disability are usually possible.

## Typical Kitchen Layouts

A kitchen is usually one of three types: the galley type with counters, appliances, and fixtures on opposite sides, a U-shape kitchen with counters, appliances, and fixtures around the U, or a 90 degree L-shaped kitchen.

Based on the disability, each individual has his/her own requirements for an accessible kitchen. However, there are some basic guidelines that help accessibility for most users.

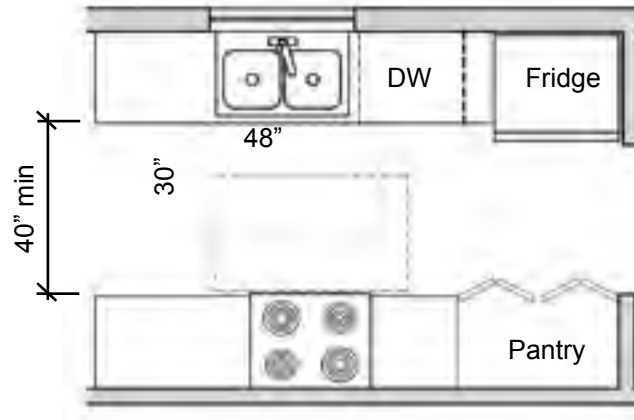

A 30" x 48" clear floor space centered on each appliance to allow for a parallel or a perpendicular approach is a basic requirement for basic usability and safe use of appliances.

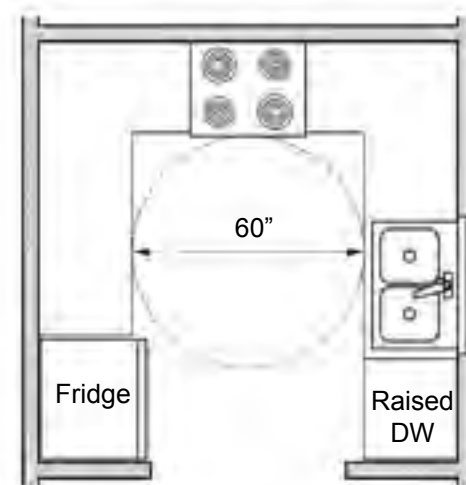

A 60" diameter turnaround is required for accessibility. Roll-under sinks, cooktops, and counters provide safety and usability.

Remove range, install  
roll under cooktop

Oven with side  
hinged door

Roll out shelf in  
upper cabinet

Refrigerator with  
bottom freezer  
drawer or side by side

Cabinet with deep  
drawers and pullout  
breadboard

Remove lower cabinet  
shelf and kick to  
provide roll-under sink

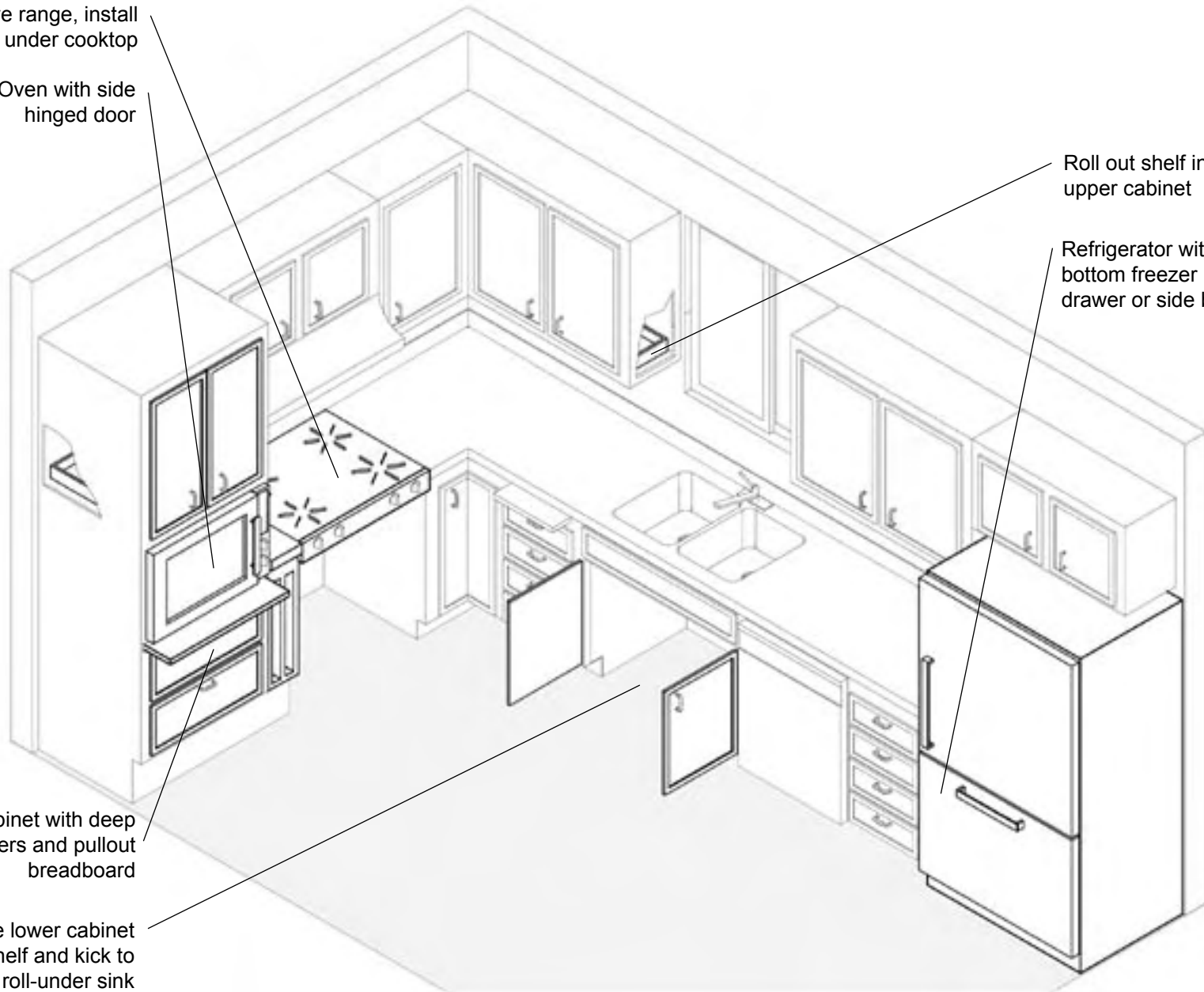

---

### Roll-Under Sinks

One of the most helpful adaptations in a kitchen is to modify the sink cabinet by removing the bottom shelf and toe kick to allow roll under space. The doors can stay or be removed.

Installing a shallow sink with a drain at the back allows for more knee clearance under the sink. The faucet hardware should be a single lever or paddle handles. It is important to insulate or cover the sink plumbing to protect the user against burns from hot water in the pipes or sink.



### Cabinets and Breadboards

Deep drawers or pull out shelves provide easier access than conventional fixed shelving. Use loop handles on cabinet doors and drawers.

Pull-out breadboards conveniently allow lower workspaces that provide an approach from three directions and can be installed throughout the kitchen.





### Ranges and Ovens

Installing a stove or cooktop with front mounted controls is another helpful adaptation for safety and ease of use.

Ovens with side swing doors and a breadboard below allow for safe transfer of hot dishes from oven to breadboard.

Microwave and oven should be mounted within easy reach.



### Shelving and Toe Space

A roll-out shelf at the bottom of an upper cabinet can provide additional reachable storage for someone using a wheelchair.

Different counter top heights (adjustable if possible) allow for different tasks. Suggested height is usually between 30" and 36" which is determined by the user. Toe space under cabinets at least 9"-12" high gives easier access to cabinets.

# NEW HOME CONSTRUCTION

---

Today, many people with a disability decide to build a new home. Some people have plans specially drawn to meet their needs. However, many stock plans can be modified to meet accessibility guidelines.

A home should be designed to the specific needs and abilities of the individual, but there are many features which are beneficial for everyone.



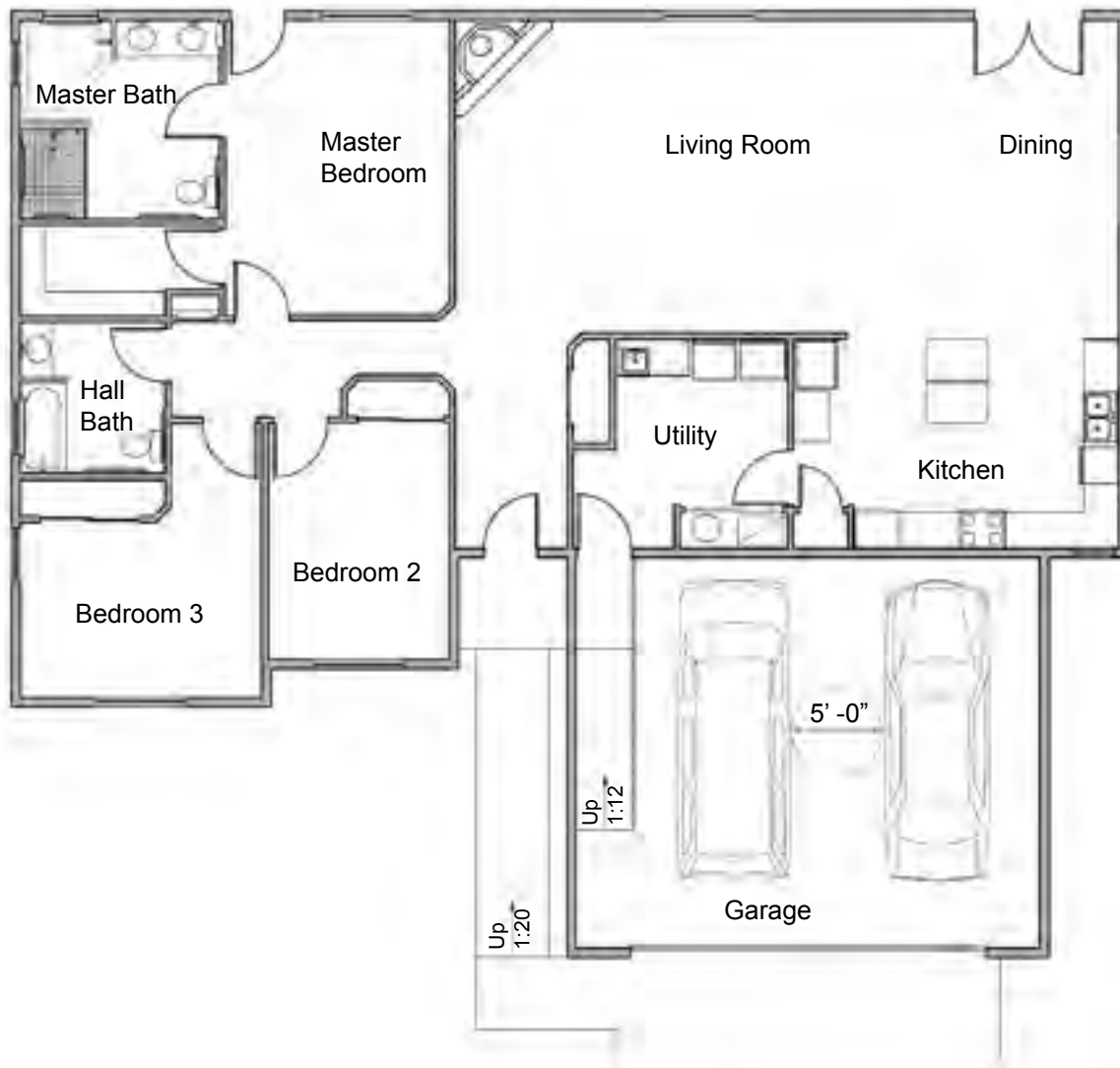

## Accessible Home Features

### No-Step Entries

Achieved with slab on grade construction, sloped pathways (1 in 20), ramps (1 in 12), or low rise framing with basement or crawl space.

### Doors

Minimum 36" wide with no or low tapered thresholds into and throughout the home with maneuvering space on latch side of door.

### Clear Floor Space

(30" x 48") by each fixture, appliance, or control and wheelchair turning space (60" diameter) at all spaces.

### Hallways

Minimum 36" wide (42"-48" preferred) and 60" turning space at end of halls. Chamfer corners for ease and wall protection.

### Switches, Outlets, and Controls

Minimum 15" and maximum 48" above floor.

### Bathrooms

Clear floor space (30" x 48") by each fixture, toilet in a 60" x 60" corner, a 60" diameter wheelchair turning space, and reinforced walls for installation of grab bars.

### Kitchen

Clear floor space at each appliance, fixture, or counter work space with roll-under sink and cooktop.

### Bedrooms

On ground floor with emergency egress door with a no-step to the exterior.

### Garage

Provide 5'-0" wide (8'-0" preferred) clear space for wheelchair access from car or van.



# No-Step Entry

## No-Step Entry Details

A no-step entry is the most important feature of a visitable or accessible home. It is also the feature that gives designers and builders the most concern in home construction. These diagrams illustrate an approach to a low rise foundation that will make a no-step entry easier to accomplish.

These details provide options for no-step entries. The typical ground floor framing leaves 20" to the finished floor, requiring steps. However, low rise framing allows for a no-step entry when entry landings are sloped to drain and a 1:20 pathway is used to slope to grade. Compacted berms can provide a transition to finish grade. The no-step entry with low rise framing requires a block-out in the foundation that allows for the placement of the concrete entry slab.

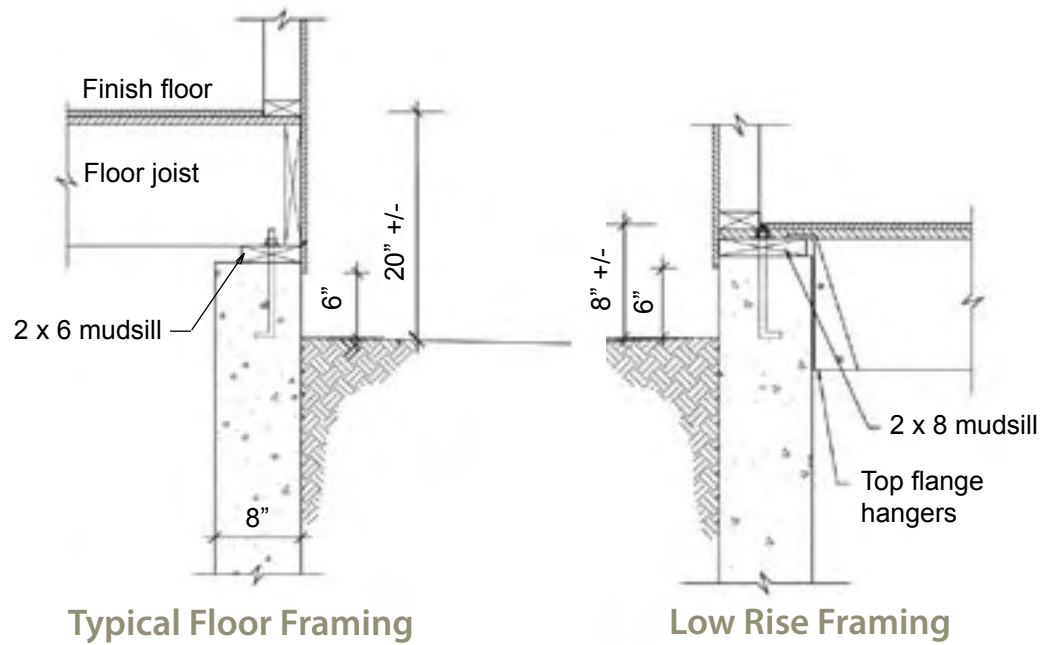

Typical Floor Framing

Low Rise Framing

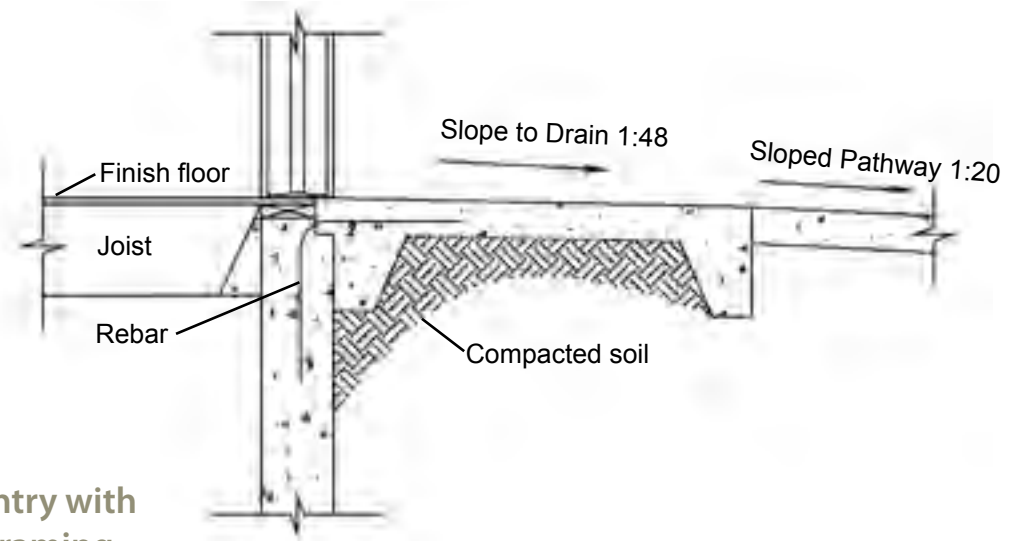

No-Step Entry with Low Rise Framing



### No-Step Entrances

No-step entries can be built into almost any new home with proper planning and design, whether they contain a basement, crawl space, or are built on slab.

The home with the sloped pathway was built with a basement. The house on the right was built on slab.

No-step entries can be at any entrance into the home; the front door, side or rear door, or garage. A no-step entry from the garage is shown. This is a multilevel house with a basement.

Since most front entrances to homes are covered, a concrete surface that is sloped to drain away from the door threshold will allow the door threshold to stay dry.



# Bathroom Access

## Bathroom Guidelines

This is a bathroom layout that provides accessibility. These features can be incorporated into new bathroom layouts according to an individual person's needs.

## Levers and Controls

Provide graspable levers and controls on plumbing fixtures, cabinets, and doors

## Roll-Under Sink

3'-0" wide with knee panel or insulation covering plumbing and mirror @ 40" above floor

## Maneuvering Space

At latch side of doors

## Wheelchair Turning Space

5'-0" diameter circle or "T"

## Clear Floor Space

30" x 48" space @ all fixtures

## Hi-rise Toilet

In 5'-0" x 5'-0" corner location that allows for left or right transfer. Toilet height 17"-19" to top of seat from floor

## Roll-In Shower

Non-skid 2 x 2 swimming pool tile with sloped marble threshold as shower lip and hand-held shower with scald guard on lever controls

## Grab Bars

Solid blocking for grab bars centered @ 3'-0" and 6'-0" above floor with 2 x 6 minimum (2 x 10 preferred). Grab bar height, orientation, and placement to comfort and strength of user

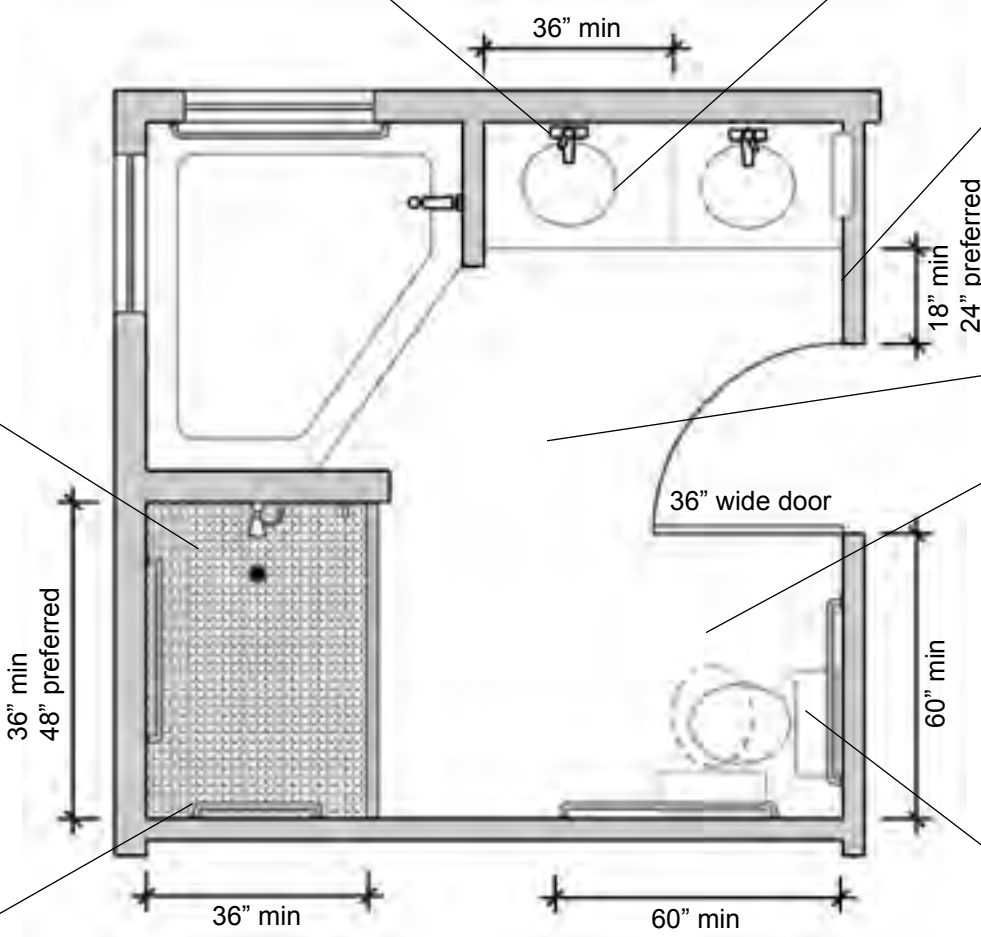

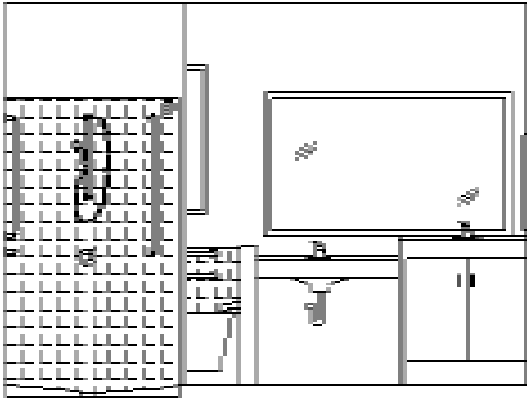

**North Elevation**

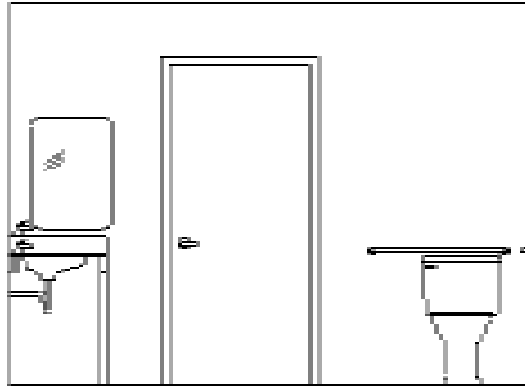

**East Elevation**

These drawings show in detail the elevations of the bathroom from the opposite page.

**North Elevation**

The grab bars and hand-held shower are shown in this view of the shower. There are double grab bars above the tub. The supplies and drain are insulated under the roll-under sink and the second sink has a 9" toe kick.

**East Elevation**

A 60" x 60" area for toilet placement provides installation on either wall depending on user ability and preference.

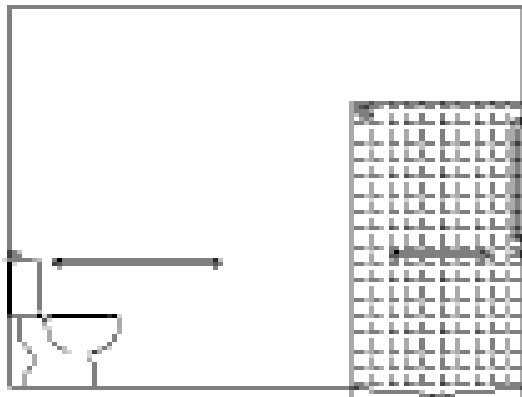

**South Elevation**

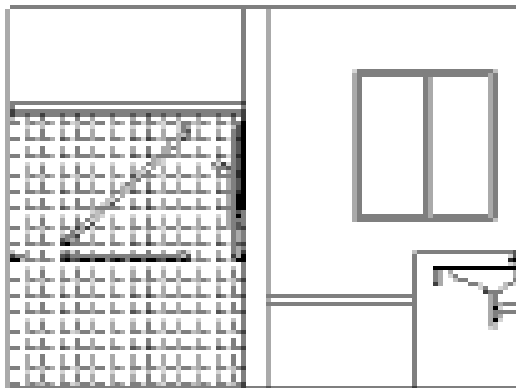

**West Elevation**

**South Elevation**

This drawing shows grab bar type and placement in the shower and at the toilet. The roll-in shower is built with a sloped marble threshold.

**West Elevation**

The diagonal bar in the shower aids a person using a shower chair in getting up and down.

---

### Transfer Space

An example is shown of a 5'x5' space which allows for fixture placement on either wall to accommodate a person's transfer abilities. A large enough bathroom with a transfer bench in a tub can provide accessibility for many.



### Roll-Under Sinks

The double sinks shown illustrate both a roll-under sink with a knee panel below and a higher second sink. This is a good option for a master bedroom. The other picture shows an offset sink. Flooring should be extended under sinks even if cabinets will be installed. This allows for easier modifications later if needed.





### **Roll-In Shower from Bedroom**

A roll-in shower can be designed using the bedroom closet to ramp up to a low shower threshold. This provides both privacy for the user and also convenient storage for the shower chair.



### **Roll-In Shower Thresholds**

In these pictures 2x2 non-skid swimming pool tile and sloped marble thresholds are shown for the roll-in showers. In both cases the drains have been lowered below floor level to provide adequate drainage for the shower.

# Kitchen Access

## Kitchen Guidelines

This is a basic kitchen layout that provides accessibility. These features can be incorporated into new kitchen layouts according to an individual user's needs.

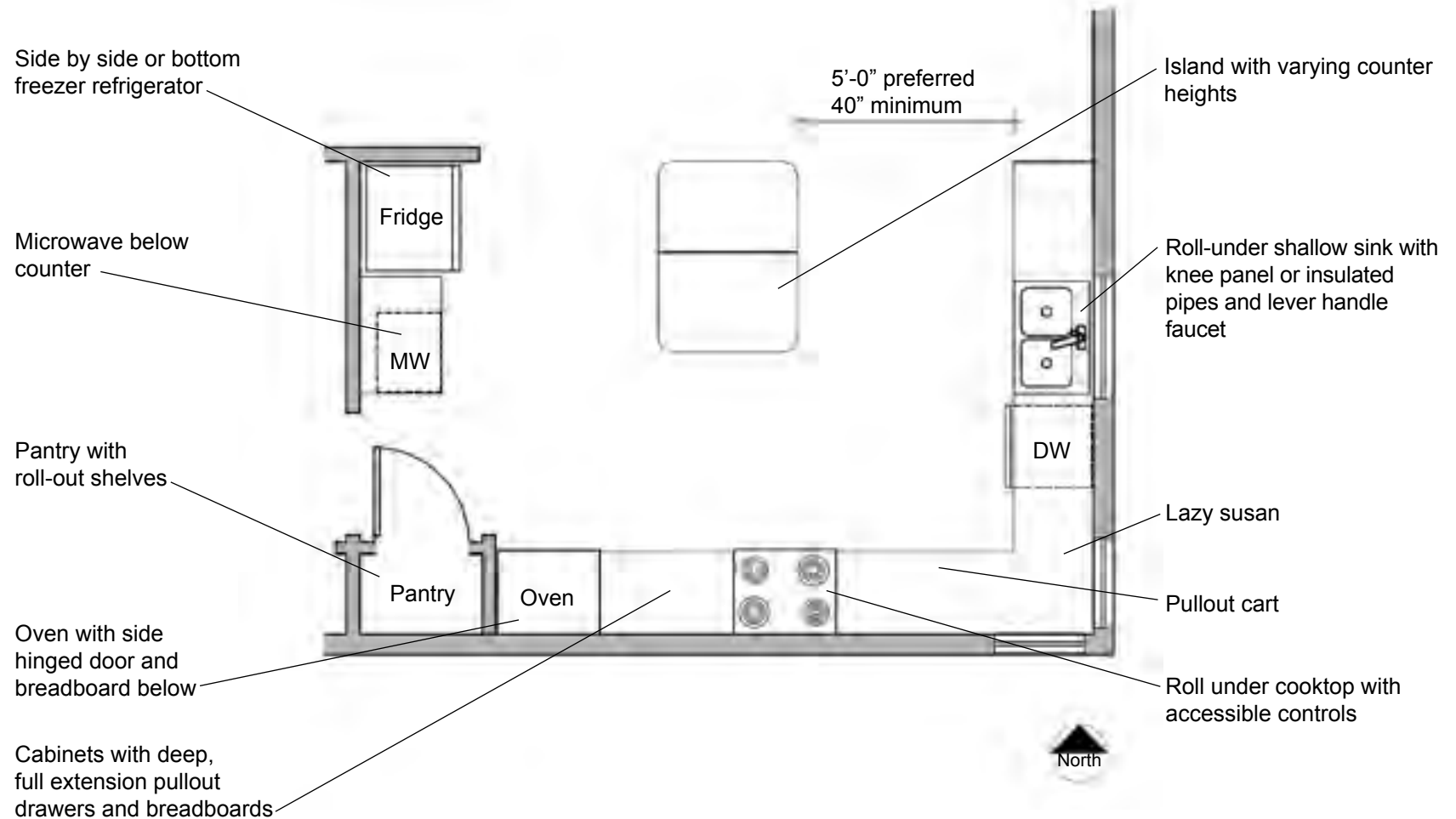

These drawings further illustrate accessibility features which include: 9" toe kicks, deep drawers, pullout shelves in upper cabinets, and loop handles.

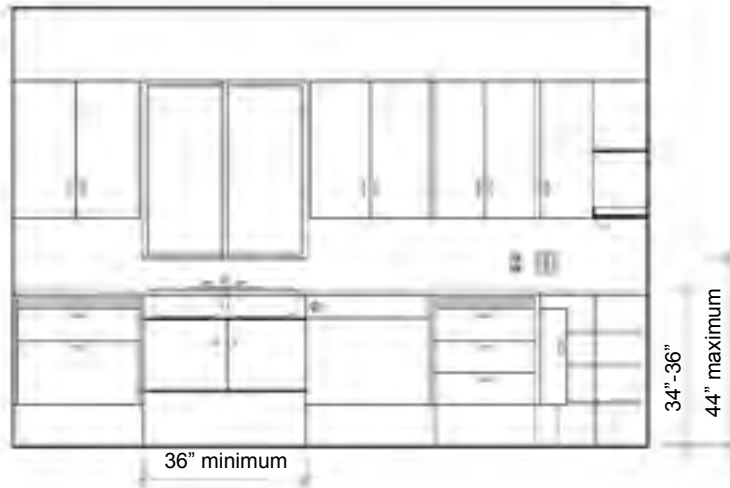

**East Elevation**



**South Elevation**

**East Wall**  
Roll-under sink  
Corner lazy susan

**West Wall**  
Lower built-in microwave  
Refrigerator with bottom freezer

**South Wall**  
Roll-out cart  
Side-hinged oven  
Roll under cooktop

**Island**  
Counter base open on 3 sides

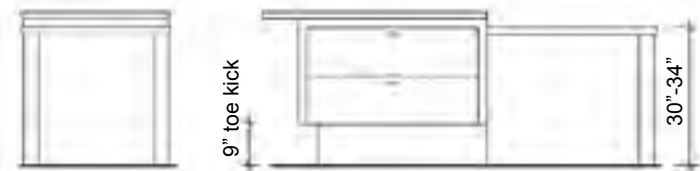

**Island Elevation**



**West Elevation**



---

### Roll-Under Counters

Counters without cabinets below can provide roll-under access for sinks, cooktops, and work surfaces. Roll-under sinks should be shallow with the drains toward the back to allow for access below the sink. The pipes can either be insulated or more ideally, a knee panel can be installed for protection. Another option is to place the faucet assembly at the side of the sink for easier access if needed.



### Cabinets and Dishwashers

Cabinets that have roll-out shelves and drawers make it easier to reach items. The open sided drawers allow for easy access into these storage areas.

Dishwashers can be placed at standard height or raised off the floor. When raised, the dishwasher racks are easier to reach.





### Ovens and Microwaves

An excellent option for ovens is a built-in oven with a side hinge door and breadboard shelf below for safety in removing hot dishes. Microwaves should be placed at wheelchair height. This example shows a deep drawer below the microwave.



### Appliances

A refrigerator with a bottom freezer places the refrigerator at a more convenient height while still allowing access to the frozen food. The solid surface roll-under cooktop allows for pans to be moved off easily. Control knobs are within reach, and could also be at the side.

## Accessible Floor Plans



This home provides easy access by placing a concrete ramp between the front door and the driveway, along the side of the typical walkway and steps. Other features include a fully accessible master bath and a usable 5' x 9-1/2' hall bathroom.



In this house a no-step entry is provided at all entrances by placing a ramp along the outside of the garage to the front porch, along the interior sidewall of the garage, and by providing doors with a no-step exit to the patio from the dining area and master bedroom.

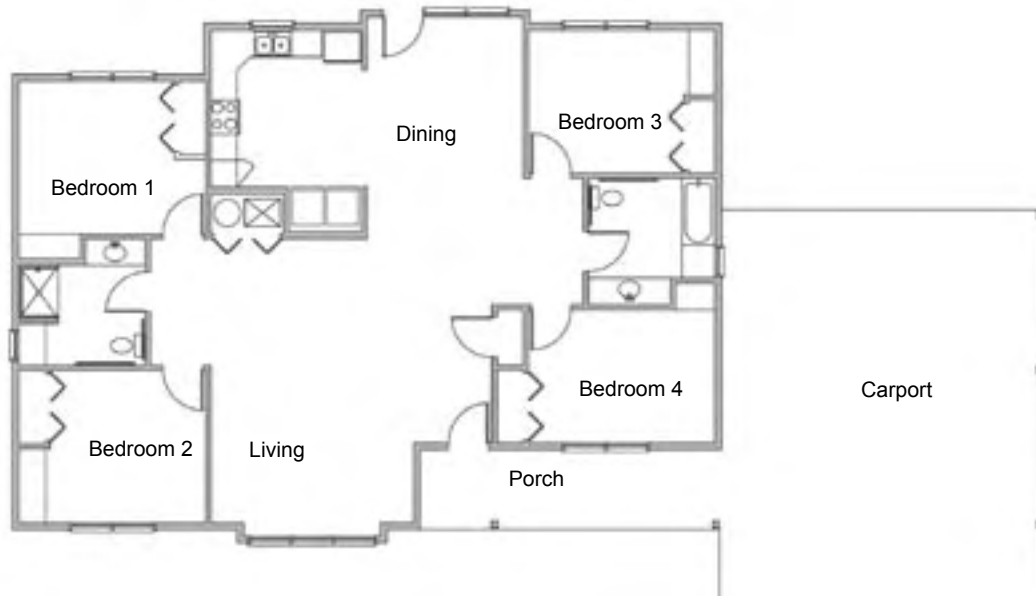

This house was designed as a four bedroom group home and provides wheelchair access based on slab on grade construction.

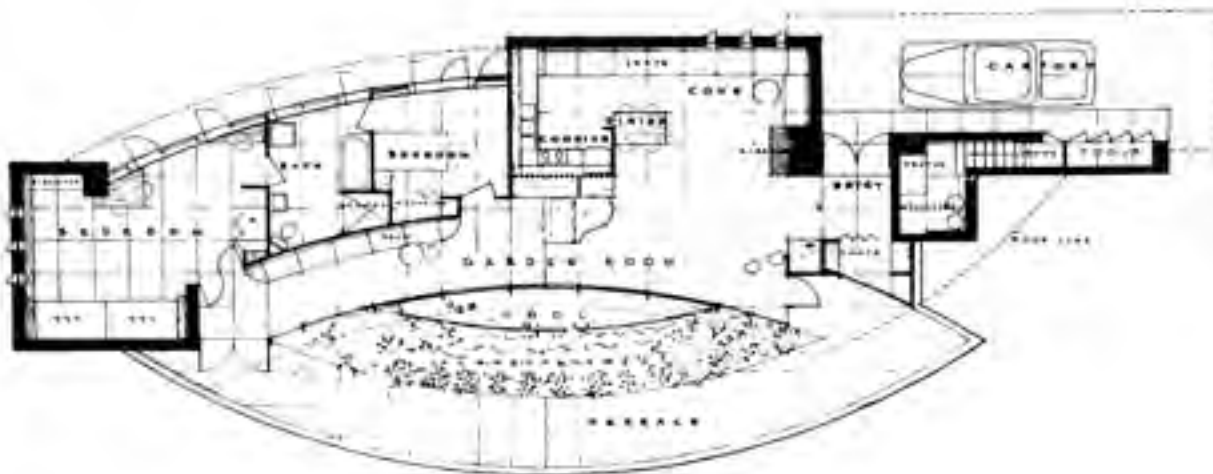

This house, designed in 1952 by Frank Lloyd Wright, was built for a man who uses a wheelchair, but you wouldn't necessarily know it. He is still living in the house.

Kenneth Laurent House, Rockford, Illinois. Cost in 1952: \$27,000

Copyright © 1954, 2002 The Frank Lloyd Wright Foundation, Scottsdale, AZ

# LEVELS OF ACCESSIBILITY

---

The barrier-free movement in the U.S. began in the 1950s when disabled veterans of both World Wars, along with other disability advocates, demanded access to education and career opportunities which were literally out of reach because of architectural barriers.

Great strides have been made over the past decades towards making our society more accessible to people with mobility impairments. The ADA (Americans with Disabilities Act) ensures that new public and commercial places are accessible. The Fair Housing Amendments Act (FHAA) and building codes require that all new multifamily housing units in new buildings with elevators be usable, a more lenient accessibility standard than full accessibility.

Surprisingly our own individual homes are still places where accessibility is the most difficult. The aging baby boomer generation and widespread desire for more independence for people with disabilities makes improved home access a market savvy approach. There are several levels of housing accessibility. These include:

**Visitability:** provides basic access features in a new home.

**Usability:** provides features for a safe and functional home.

**Accessibility:** provides maneuverability and independence in a home.

## Visitability Features

Visitability is a housing design concept that extends the welcome of our homes to family and friends with disabilities. Visitability of a home means that there is at least one no-step entry somewhere into the home, there are adequate passage doors, and a usable ground floor bathroom that allows a person using a wheelchair to enter and close the door. This can be achieved even in small bathrooms and half baths by hinging the door to swing out as it does with closets.

Visitability has many partners and advocates. Designers, builders, and public officials have begun to see the common sense of Visitability. This movement draws from the tradition of Universal Design, serving people of all ages, sizes, and abilities.

In 1992 the first city Visitability ordinance in the U.S. was passed in Atlanta, Georgia, the home state of Eleanor Smith, founder and director of "Concrete Change". The strategy of the Visitability movement is to prioritize the three most essential access features - one zero-step entry, all interior doors with at least 32" of clear passage space, and a usable bathroom on the main floor - and to press vigorously through legislation and other means for the widespread application of these features.

In 1997 Great Britain adopted the Single-Family Access Law creating a level of

access for all new homes throughout England and Wales. Over a dozen Visitability initiatives have been passed in the U.S. The first Visitability laws that applied to all single family homes (not just those funded with public money) passed in Pima County, AZ and Bolingbrook, IL in February 2002. The Florida Bathroom Law of 1989 was the first state level accessibility requirement applied to all new single family homes.

## Usability Features

Beyond the three essential features of visitability, usability features, such as higher outlets and lower thermostats, and backing for grab bars in tubs can be easily incorporated. Usability features are essentially equivalent to the requirements of the Fair Housing accessibility guidelines and the requirements for Type B (Usable) dwelling units in the 2003 International Building Code (IBC).

## Accessibility Features

The 2003 IBC also requires that at least 2% of the dwelling units in a structure with 20 or more units include accessible features beyond the usable features. Federal, state, and local housing funding programs usually require greater levels and percentages of accessible units. The accessibility requirements normally used are the Uniform Federal Accessibility Standards (UFAS).

# Seven Fair Housing Accessibility Requirements

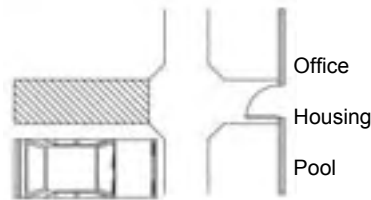

**Accessible entrance on an accessible route**  
*At least one entrance to a multiple unit building must be accessible from significant locations.*

**Accessible public and common use areas**  
*Parking areas, rental offices, public use restrooms, and common use buildings must be accessible.*

**Usable Doors**  
*Entry doors shall provide 32" clear opening (36" door required) and all interior passage doors shall provide 31-3/4" minimum clear opening (34" door required).*

**Accessible routes into and through the dwelling unit**  
*Minimum clear width of hallways is 36". Thresholds to be 1/2" max or 3/4" at sliding doors with beveled thresholds.*

**Accessible light switches, outlets, and environmental controls**  
*All controls, switches, and outlets must be a minimum of 15" and a maximum of 48" above the floor. A 30" x 48" parallel or forward approach clear space is required for controls.*

**Reinforced walls for grab bars**  
*Reinforcement shall be provided in bathrooms for the installation of grab bars.*

**Usable kitchens and bathrooms**  
*Provide 30" x 48" clear floor space for parallel or forward approach centered at each kitchen appliance and bathroom fixture.*

In 1988 Congress passed the Fair Housing Amendments Act (FHAA) requiring that new multifamily housing consisting of four or more dwelling units contain basic accessibility features. The FHAA was intended to provide usable housing for persons with disabilities, thereby ending discrimination by design that prevented people using wheelchairs from entering or renting housing.

The FHAA requires that in elevator buildings with four or more units, **ALL** units must be safe and usable by people with infirmities or disabilities. The U.S. Department of Housing and Urban Development (HUD) issued the Fair Housing Act Design Manual that provides design and construction guidelines to meet the Seven Technical Requirements of the FHAA.

The 2003 International Building Code (IBC) also requires that "Where there are four or more dwelling units in a single structure... **EVERY** dwelling unit shall be a Type B dwelling unit". Type B unit requirements are essentially equivalent to the accessibility features required by the FHAA.

The IBC and FHAA also require that, "Where no elevator service is provided in a building... at least one story containing dwelling units shall be provided with an accessible entrance from the exterior of the building and **ALL** units on that story shall be Type B units (Usable)". (*Emphasis added*)

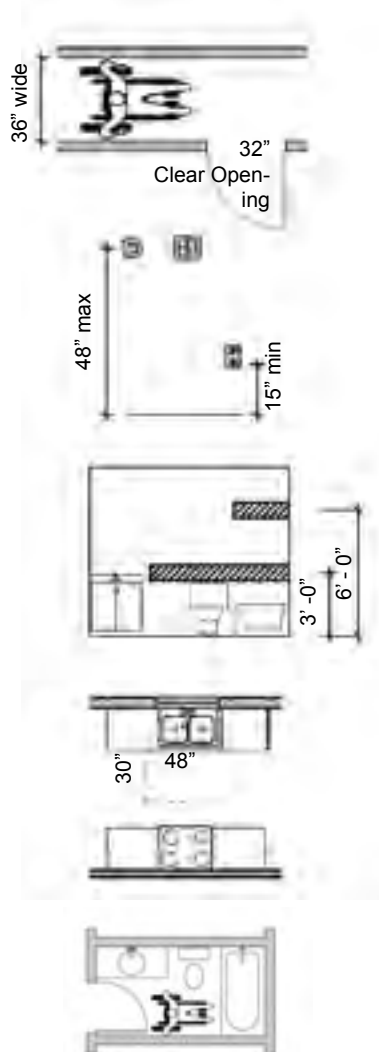

# VISITABILITY FEATURES

## Essential Visitability Features

The three Essential Visitability Features are illustrated here and it is recommended that they be offered as an amenity package by architects, designers, and home builders to all their clients to enhance the livability and future value of the home. The EasyLiving Home program that started in Georgia is promoting a voluntary certification program to promote "EasyLiving features that make a home cost effective, attractive, visitable, and convenient for everyone".

The Visitability features are easy to incorporate in new homes and are rarely noticed as "special features". As we age, the accessibility of our homes may become a decisive factor in enabling us to remain in our own homes. Incorporating Visitable features into a new home enables people to stay in their homes without expensive remodeling for accessibility.

Current numbers of older adults are expected to double to over 70 million by 2030. Utah is projected to lead this trend as residents age-in-place, and as the "age wave" of retirees heads west. The overwhelming majority of older adults express a desire to remain in their own homes and live as independently as possible. In addition, the inability to visit the homes of friends and family can lead to isolation, a serious risk factor for poor health.

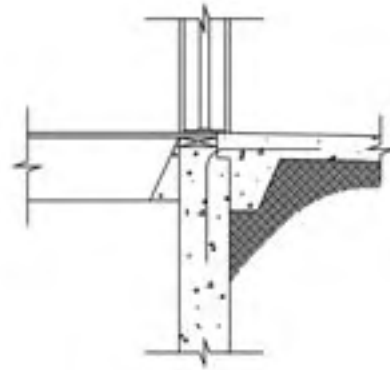

No-Step Entry

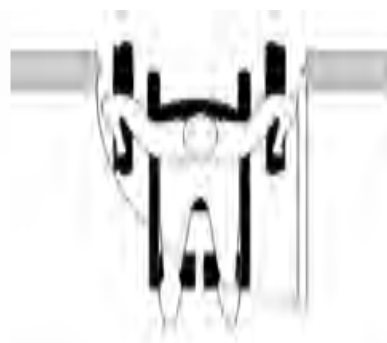

Adequate Doorways

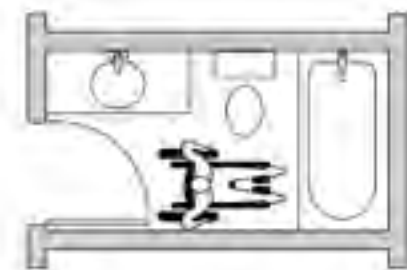

Usable Bathroom





Easy for Families



Easy for Seniors



Easy for All



Visiting Family



Visiting Friends



Visiting All Homes



# USABILITY FEATURES

The Usability features shown on this page, when combined with the essential Visitability features, make homes usable for many persons with disabilities. The Usability features are easy to incorporate into new homes and are rarely noticed as “special features”.

The design features illustrated here are essentially equivalent (with the exception of the ground floor bedroom) to the accessibility requirements of the Fair Housing Amendments Act for dwelling units in multifamily buildings with four or more units and building code requirements for Usable units.

In an effort to clarify and coordinate the requirements for Accessible and Usable housing, HUD and the International Code Council have worked together to synchronize the FHAA accessibility requirements with the code requirements for Usable (IBC Type B) dwelling units. HUD has recognized that the IBC, with updates, is a “safe harbor” for meeting the FHAA. This should greatly simplify the requirements and help in Fair Housing accessibility compliance.

## Accessible Route Into and Through the Dwelling Unit

A 36” wide hall has already become a minimum standard and enables wheelchair passage throughout the dwelling. The preferred width is 42” to 48”.

## Accessible Switches, Outlets & Controls

Mounting controls at 15” minimum and 48” maximum above floor and providing 30” x 48” clear space for approach insures that light switches, thermostats, and electrical outlets can be easily reached.

## Reinforced Walls for Grab Bar Installation

This allows for installation of supportive grab bars to prevent falls or facilitate transfers. 2”x10” solid blocking is recommended around bathroom walls. A row centered at 3’-0” above the floor and another row in the tub and shower areas centered at 6’-0” above the floor enables flexibility for grab bar placement.

## Usable Kitchens

A 30” x 48” clear floor space centered at each appliance, fixture, or counter area enables a person in a wheelchair or a walker to use those fixtures and appliances. These spaces can overlap each other.

## Ground Floor Bedroom

An additional room on the ground floor that can be used as a bedroom.

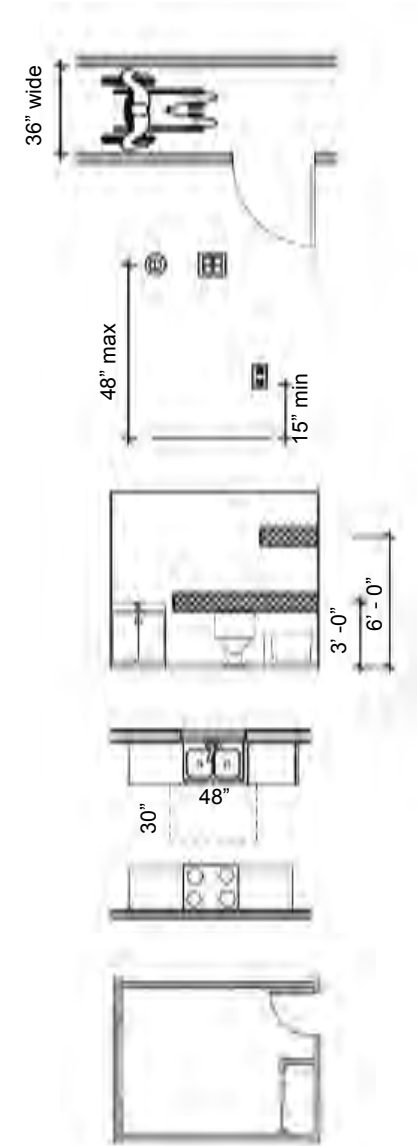

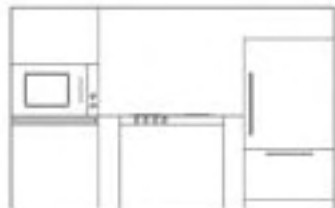
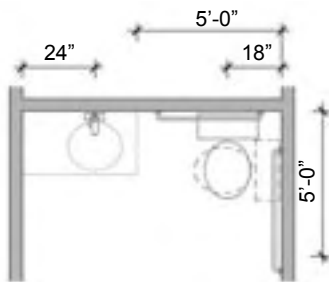
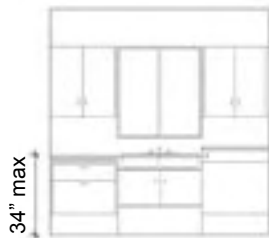
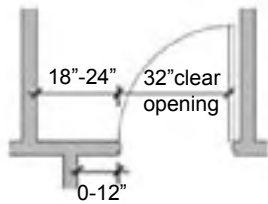
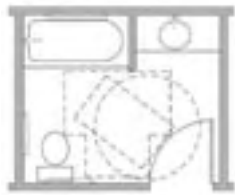

### Wheelchair turning space

60" diameter wheelchair turning space or "T" wheelchair turning space, including 30" x 48" clear floor space beyond the swing of the door.

### Doors

Latch side maneuvering space and lever handles on all passage doors.

### Kitchen

Counters at 34" high and sinks at 6 1/2" maximum depth with knee and toe space.

### Bathroom fixture spacing

Toilets 16"-18" from sidewall or fixtures. Toilets to be placed in a corner of the bathroom with 5'-0" of wall in both directions. This enables setting the toilet for either a right or left transfer. Mirrors in bathroom 40" max above floor. Grab bars installed.

### Controls

All appliance controls, window handles, etc. need to be in accessible locations and operable. Half of the freezer compartment must be below 54".

### Communication devices

Accessible communication features, such as visual and audible smoke alarms and doorbells, may need to be installed when requested by residents in eligible units.

The 2003 IBC requires that in multifamily buildings with more than 20 units, at least 2% of those units must be Type A units. Type A is more accessible than the Usable (Type B) standard, including, for example, providing a wheelchair turning space in all rooms and in at least one bathroom in the unit.

In addition to the FHAA and IBC accessibility requirements, federal, state and local housing funding programs require greater levels and percentages of accessible units. These requirements for housing for seniors or people with disabilities usually follow the more fully accessible requirements of the Uniform Federal Accessibility Standards (UFAS) that require, for example, that grab bars be installed in showers and roll-under sinks be provided.

The technical standards for Accessible and Usable dwelling units are found in the International Code Council / American National Standard, Accessible and Usable Buildings and Facilities, ICC/ANSI A117.1, commonly known as the "ANSI Standard". Chapter 10 of ANSI A117.1 contains the requirements for Type A, Type B, and Accessible units.

# Resources

---

## Resources in Utah

### **ACCESS Utah**

155 South 300 West Suite 100  
Salt Lake City, UT 84101  
www.accessut.org

(801) 533-4636  
(800) 333-8824

Information and referral on services for people with disabilities.

### **Accessible Homes Foundation**

P.O. Box 26383  
Salt Lake City, UT 84126-0383  
www.accessshomes.org

Promoting development of accessible homes.

### **ASSIST Inc**

218 East 500 South  
Salt Lake City, UT 84111  
www.assistutah.org

(801) 355-7085  
(877) 265-4287

Architectural design for home accessibility. Anyone in the state is eligible for consultation and design service. In addition, low income households (below 50% of area median income); in Salt Lake City, South Salt Lake, Murray, Sandy, West Jordan, Midvale, Draper, Taylorsville, and unincorporated areas of Salt Lake County may be eligible for a grant or deferred payment loan to pay for accessibility modifications.

### **Center for Persons with Disabilities**

Utah Assistive Technology Program  
6800 Old Main Hill  
Logan, Ut 84222-6800  
(866) 284-2821  
www.cpd.usu.edu

Information on accessible design, environmental accommodations, and assistive technology.

### **Community Development Corporation of Utah**

501 East 1700 South  
Salt Lake City, Ut 84105  
www.slcdc.org

(801) 994-7222

Mission is to provide home ownership opportunities statewide for low and moderate income families through housing rehabilitation or new construction, including barrier free homes.

### **Community Services Council**

1025 South 700 West  
Salt Lake City, UT 84104  
www.csc-ut.org

(801) 978-2452

Support services offer minor home repairs, electrical and plumbing repairs, painting, and minor appliance repair for elderly and disabled individuals in Salt Lake County, through the Lifecare program.

### **Disability Law Center**

205 North 400 West  
Salt Lake City, UT 84103  
www.disabilitylawcenter.com

(801) 363-1347  
(800) 662-9080

Legal resource for people with disabilities in relation to housing, employment, and accessibility issues.

### **Disabled Rights Action Committee**

3565 South West Temple #16 TDD/ Voice (801) 685-8214  
Salt Lake City, UT 84115 UT Toll Free (800) 478-9314  
email: dracslc@peoplespc.com (801) 685-8216 Fax

The Disabled Rights Action Committee is committed to expanding and assuring the rights of people with disabilities and to working for total accessibility in the workplace, housing, transportation, and all public areas.

---

**Easter Seals Utah**

638 E. Wilmington Ave.  
Salt Lake City, UT 84106  
www.eastersealsutah.org

(801) 486-3778  
(800) 388-1991

Mission is to help people with disabilities achieve independence.

**INDEPENDENT LIVING CENTERS:**

Community-based, consumer-oriented Independent Living Centers help people with disabilities achieve or maintain self-sufficient and productive lives in their own communities. Assistive technology, funding information, referrals to agencies and resources are services provided by the centers.

**Active Re-Entry Independent Living Center**

10 South Fairgrounds Road  
Price, UT 84501-3226  
(435) 637-4950  
Email: active@arecil.org

**Active Re-Entry Satellite Office in Uintah Basin**

510 East Main, Suite 3  
Vernal, UT 84078  
(435) 789-4021  
email: active@easilink.com

**Active Re-Entry Satellite Office in Moab**

125 West 200 South - Room 106B  
Moab, UT 84542  
(435) 259-0245

**Central Utah Center for Independent Living**

491 North Freedom Blvd  
Provo, UT 84601  
373-5044  
www.cucil.org

(801)

**Options for Independence**

1095 North Main  
Logan, UT 84341  
753-5353  
www.optionsind.org  
email: jbiggs@optionsind.org

(435)

**Options for Independence Satellite in Box Elder County**

416 East 850 South - Room 106  
Brigham City, UT 84302

(435) 723-2171

**Red Rock Independent Living Center**

515 West 300 North, Suite A  
St. George, UT 84770-4555  
www.rrci.org

(435) 673-7501  
(800) 649-2340

**Tri-County ILC of Utah**

705 - 40th Street  
Ogden, UT 84401  
email: ilc456@aol.com

(801) 612-3215

**Utah Independent Living Center**

3445 South Main Street  
Salt Lake City, UT 84115-4453  
email: uilc@xmission.com

(801) 466-5565

**Utah Center for Assistive Technology**

1595 West 500 South  
Salt Lake City, UT 84104  
887-9500 www.usor.utah.gov  
(888) 866-5550

(801)

The Center is a statewide resource providing information and technical services that assist people with disabilities in the acquisition and utilization of assistive technology.

---

**Utah Governor's Council for People with Disabilities**

155 South 300 West, Suite 100 (801) 533-3965  
Salt Lake City, UT 84102 (800)  
333-8824  
www.gcpd.org Language Line (801) 533-4636

Mission is to create an environment in which people with disabilities direct their own lives and participate in the community. The council achieves this through facilitating interagency and citizen planning, identifying needs, recommending policy, promoting partnerships, providing advocacy, and evaluating and improving support systems.

**Utah Division of Services for People with Disabilities**

120 North 200 West, Rm 411  
Salt Lake City, Utah 84103 (801) 538-4200  
www.hsdspd.utah.gov (800) 837-6811

|                              |                             |
|------------------------------|-----------------------------|
| American Fork (801) 763-4100 | Nephi (435) 623-2431        |
| Blanding (435) 678-1440      | Ogden (801) 626-3300        |
| Brigham City (435) 734-4075  | Price (435) 636-2390        |
| Cedar City (435) 865-5650    | Provo (801) 374-7005        |
| Clearfield (801) 776-7300    | Richfield (435) 896-1281    |
| Delta (435) 864-3869         | Salt Lake City (801)        |
| 264-7620                     |                             |
| Heber (435) 657-4206         | Spanish Fork (801) 749-6700 |
| Layton (801) 779-6700        | St. George (435) 674-3961   |
| Logan (435) 787-3450         | Tooele (435) 833-7355       |
| Manti (435) 835-0795         | Vernal (435) 789-9336       |
| Moab (435) 259-3728          |                             |

Mission is to promote opportunities and provide support for persons with disabilities to participate fully in Utah life. The regional offices of the Division oversee community programs for over 3200 citizens with developmental disabilities which qualify them to receive Division services. Services include support for families, residential options, and day services.

**Utah State Office of Rehabilitation**

250 East 500 South  
Salt Lake City, UT 84111 (801) 538-7530  
www.usor.utah.gov (800)473-7530

|                              |                |          |
|------------------------------|----------------|----------|
| Southern Utah (435) 586-9995 |                |          |
| Provo                        | (801) 374-7724 | Northern |
| Utah (435) 395-6310          |                |          |
| Ogden                        | (801) 395-7020 | West     |
| Valley (801) 957-8200        |                |          |
| Vernal                       | (435) 789-0273 | South    |
| Salt Lake (801) 267-5600     |                |          |
| Moab                         | (435) 259-4635 | Eastern  |
| Utah (435) 636-2820          |                |          |

May provide assistance for home modifications and assistive technology for clients. Modifications must be related to enabling employment.

---

## Financial Assistance for Home Modifications and Assistive Technology

**ASSIST Inc,** (801) 355-7085  
Salt Lake City, Utah Toll Free (877) 265-4287

Accessibility assessment and design assistance provided at no cost. Some grants and deferred payment loans for home accessibility modifications in most of Salt Lake County for lower income households.

### City or County Housing Authorities

Throughout Utah Check phone books for current numbers

Housing Authorities in various cities and counties throughout the State of Utah often provide grants or loans for housing repair or rehabilitation needs including accessibility modifications.

### Independent Living Centers

Throughout Utah See pages 85 for phone numbers

Funding for assistive technology

### Community Services Council - Lifecare

Salt Lake City, Utah (801) 978-2452

Minor repairs for elderly low income residents or persons with disabilities including grab bars and door modifications for households in most of Salt Lake County.

### Utah Assistive Technology Foundation

Logan, Utah (435) 797-2355  
Toll Free (866) 284-2821

Provides zero percent loans to purchase assistive devices and home modifications. Low interest loans for van modifications and partial grants.

### Utah Center for Assistive Technology

Salt Lake City, Utah  
(801) 887-9500 Toll Free (888) 866-5550

Assistance for acquisition and utilization of assistive technology.

### Utah Division of Services for People with Disabilities

Salt Lake City, Utah  
(801) 538-4200 See page 86 for regional offices

### Utah State Office of Rehabilitation

Salt Lake City, Utah  
(801) 538-7530 See page 86 for regional offices

# References

---

## Publications

**Accessible Home Design: Architectural Solutions for the Wheelchair User**, T. Davies, K. Beasley, Paralyzed Veterans of America, 1999.

**Accessible Housing**, Leon A. Frechette, McGraw-Hill, 1996.

**Accessible Housing by Design**, Steven Winter Associates, McGraw-Hill, 1997.

**An Accessible Entrance: Ramps**, Karen Nickels, Design Coalition, Inc., 1201 Williamson St., Madison, Wisconsin, 1982.

**Barrier Free Design**, James Holmes Siedle, Butterworth Architecture, London, 1996.

**Beautiful Barrier Free**, Cynthia Leibrock, Van Nostrand Reinhold, New York, 1993.

**Building Design for Handicapped and Aged Persons**, Council on Tall Buildings and Urban Habitat Committee 56, McGraw-Hill, 1992.

**Designs for a Lifetime: The Expanding Appeal of Universal Design**, NAHB, National Council on Senior Housing, 1999.

**Design for Accessibility**, Robert James Sorensen, McGraw-Hill, 1979.

**Design for Aging: An Architect's Guide**, The American Institute of Architects, The AIA Press, 1985.

**Design for Independent Living, The Environment and Physically Disabled People**, Raymond Lifchez and Barbara Wilslow, The Architectural Press, London, 1979.

**Homes that Help: Advice from Caregivers for Creating a Supportive Home**, Richard Olsen, Ezra Ehrenkrantz, Barbara Hutchings, New Jersey Institute of Technology, 1993.

**How to Build Ramps**, The Ramp Project, Metropolitan Center for Independent Living, St. Paul, Minnesota.

**Practicing Universal Design, An Interpretation of the ADA**, William L. Wilkoff and Laura W. Abed, Van Nostrand Reinhold, New York, 1994.

**Residential Remodeling and Universal Design: Making Homes Comfortable and Accessible**, NAHB Research Center, Upper Marlboro, MD., Barrier Free Environments, Inc., Raleigh, NC, 1996.

**The Accessible Bathroom**, Design Coalition, Inc., 2088 Atwood Avenue, Madison, Wisconsin, 1991.

**The Accessible Housing Design File**, Ronald L. Mace, Barrier Free Environments, Inc., Van Nostrand Reinhold, New York, 1991.

**The Complete Guide to Barrier Free Housing**, Gary D. Branson, Betterway Publications, Inc., White Hall, Virginia, 1991.

**The Do-Able Renewable Home**, John P. S. Salmen, American Association of Retired Persons, 1988.

**Universal Kitchen and Bathroom Planning: Design that Adapts to People**, Mary Jo Peterson, McGraw-Hill, 1998.

**Visit-ability: An Approach to Universal Design in Housing**, Steven Truesdale, Edward Steinfeld, Rehabilitation Engineering Research Center on Universal Design, Buffalo, NY.

## Design Guidelines

**ADAAG Manual: A Guide to the Americans with Disabilities Act Accessibility Guidelines**, U.S. Architectural and Transportation Barriers Compliance Board, 1998.

**Code Requirements for Housing Accessibility**, International Code Council, 2000.

**Doors, Tech Sheet Series**, The Americans with Disabilities Act Accessibility Guidelines, Barrier Free Environments, Inc., 1995.

**Fair Housing Accessibility Guidelines: Seven Requirements of the Fair Housing Act**, U.S. Dept. of Housing & Urban Development, 1991.

**ICC/ANSI A117.1-2003**, International Code Council/American National Standards Institute, Accessible and Usable Buildings and Facilities, International Code Council

**International Building Code 2003**, International Code Council.

---

**Recommendations for Accessibility Standards for Children's Environments**, U. S. Architectural and Transportation Barriers Compliance Board, 1331 F Street, NW, Suite 1000, Washington, D. C. 20004-1111, October, 1995.

**The Fair Housing Act Design Manual: A Manual to Assist Designers and Builders in Meeting the Accessibility Requirements of the Fair Housing Act**, Barrier Free Environments for the US Dept. of Housing & Urban Development, 1998.

**Uniform Federal Accessibility Standards, General Services Administration**, Department of Defence, Department of Housing and Urban Development, and U. S. Post Office: U. S. Gov Printing Office, 1990.

**1997 Uniform Building Code, Volume I**, International Conference of Building Officials, 5360 Workman Mill Rd., Whittier, California.

## Technical Assistance

### Adaptive Environments

374 Congress St., Ste. 301  
Boston, MA 02210  
www.adaptenv.org

(617) 695-1225

Offers a publication with information on home adaptation for persons with disabilities with lists of products and assistance resources.

### ASSIST Inc

218 East 500 South  
Salt Lake City, UT 84111

(801) 355-7085  
(877) 265-4287

Offers accessibility assessment and design services, conducts training workshops and presentations on home modifications and accessible housing, and distributes this Guidebook.

### Center for Universal Design NC State University College of Design

Campus Box 7701  
Raleigh, NC 27695-8613  
www.design.ncsu.edu

(800) 647-6777

The center develops publications and instructional materials, and provides information, referrals, and technical assistance to individuals with disabilities, their families, and professionals nationwide.

### Concrete Change

600 Dancing Fox Road  
Decatur, GA 30032  
www.concretechange.org

(404) 378-7455

Website offers free construction information for VISIBLE homes and suggestions for becoming active in the movement for home construction change.

### Paralyzed Veterans Association

75-20 Astoria Boulevard  
Jackson Heights, NY 11370-1177  
www.pva.org

(718) 803-3782

Resource information including videos and printed matter on planning for accessibility.

### Center for Inclusive Design & Environmental Access Idea Program

School of Architecture and Planning  
State University of New York at Buffalo  
Buffalo, NY 14214  
www.ap.buffalo.edu

(716) 829-3485

The Center is active in basic and applied research, architectural design, community service and education. Programs focus on home modifications, functional assessment, and universal design.

### National Council on Independent Living

1916 Wilson Blvd., Ste. 209  
Arlington, VA 22201  
www.ncil.org

(703) 525-3406

Provides technical assistance to independent living centers located throughout the United States.

### Rocky Mountain Technical Assistance Center

3630 Sinton R., Suite 103  
Colorado Springs, CO 80907  
www.ada-infonet.org

(800) 949-4232

**Official information resource center on ADA issues for the Intermountain West.** Provided at no cost. Funded by the Department of Education.



# Index

---

|                           |            |                            |          |                     |           |
|---------------------------|------------|----------------------------|----------|---------------------|-----------|
| Bathrooms                 |            | refrigerator               | 61       | metal/modular       | 41        |
| counter heights           | 5, 57      | roll-under sinks           | 61-62    | new stairs          | 38-39     |
| curb shower               | 55-56, 58  | toe space                  | 63       | planning            | 10        |
| floor space               | 5          | Levels of Accessibility    | 78       | plywood framing     | 20        |
| grab bars                 | 5, 57      | Seven Fair Housing         |          | plywood section     | 21, 26    |
| hand held shower          | 57         | Accessibility Requirements | 79       | portable            | 41        |
| roll-in shower            | 55-56, 59, | accessibility features     | 83       | railings            | 4, 23, 39 |
| 71                        |            | usability features         | 82       | rise                | 12-13     |
| roll-under sink           | 57, 59, 70 | visitability features      | 80-81    | slope               | 4, 13     |
| sink height               | 5          | Lifts                      |          | site considerations | 11        |
| tub seat                  | 54, 58     | elevators                  | 53       | site measurements   | 15        |
| transfer bench            | 54, 58     | inclined platform lift     | 52       | structural supports | 22        |
| Doors                     |            | porch lift                 | 7, 48-49 | surface             | 47        |
| accordion door            | 50         | overhead lift              | 52       | transitions         | 28-31     |
| bifold doors              | 50         | stair lift                 | 52       | weather             | 10        |
| door stops                | 51         | Low Rise Steps             | 7, 44-45 | wedges              | 37        |
| exterior                  | 10         | New Home Construction      | 64       | width               | 4         |
| handles                   | 51         | accessible features        | 65       | References          | 88-89     |
| keyless entry             | 51         | bathroom                   | 68-71    | Resources in Utah   | 84-87     |
| locks                     | 51         | house plans                | 76-77    | Steps               | 38-39     |
| maneuvering space         | 5          | kitchen                    | 72-75    | Standard Dimensions | 4-5       |
| opening width             | 5, 50      | no-Step entry              | 66-67    | Thresholds          | 4, 37     |
| pocket door               | 50         | porches                    | 36-37    | Typical Homes       | 8-9       |
| sliding glass doors       | 50         | Ramps                      | 4, 6     |                     |           |
| standard door             | 50         | 2x4 framing                | 40       |                     |           |
| swing clear hinges        | 51         | 2x6 section                | 27       |                     |           |
| thresholds                | 4, 37      | concrete                   | 42-43    |                     |           |
| widening                  | 51         | curbs                      | 4        |                     |           |
| Fair Housing requirements | 79         | finishes                   | 47       |                     |           |
| Introduction              | 2          | footings                   | 24-25    |                     |           |
| Kitchens                  |            | from deck                  | 17       |                     |           |
| breadboards               | 61-62      | hardware                   | 46       |                     |           |
| cabinets                  | 61-62      | in garage                  | 17       |                     |           |
| controls                  | 63         | landings                   | 4, 32-35 |                     |           |
| cooktop                   | 61         | layouts                    | 16-19    |                     |           |
| counter heights           | 63         | length                     | 4, 14    |                     |           |
| layouts                   | 60         | lumber                     | 46       |                     |           |
| ranges/ovens              | 61, 63     | materials                  | 47       |                     |           |